

Technical Data

For wood chip and pellet firing

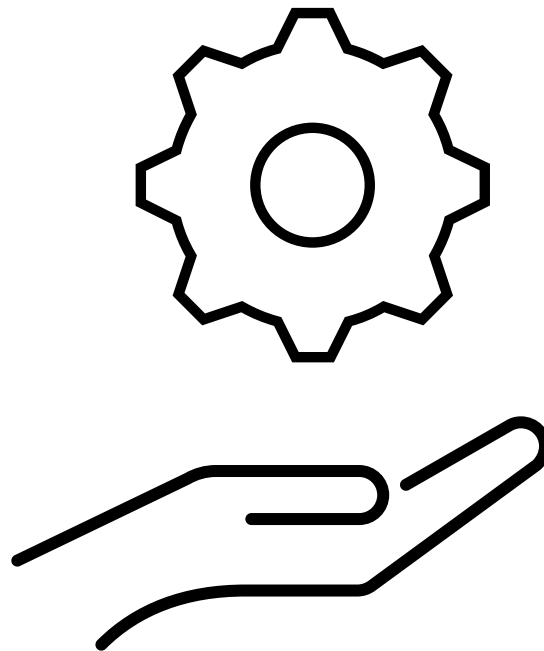

UTSD 240
(110– 260 kW)

Table of Contents:

Chapter Description Page

1	Brief description of the UTSD boiler system	5
1.1	General information	5
1.2	Equipment characteristics and scope of delivery	5
1.2.1	Boiler body	5
1.2.2	Casing	5
1.2.3	Combustion technology	6
1.2.4	Combustion chamber	6
1.2.5	Standard ash removal system	6
1.2.6	Cleaning system	6
1.2.7	Stoker worm gear unit	6
1.2.8	Safety equipment	7
1.2.9	Control unit	8
1.3	General classification of UTSD / technical data	11
1.3.1	Sectional view UTSD	12
1.3.2	Main dimensions	12
1.3.3	Technical data in general	13
1.3.4	Technical data for wood chips as fuel	16
1.3.5	Emission data for wood chips as fuel	17
1.3.6	Technical data for pellets as fuel	19
1.3.7	Emission data for pellets as fuel	21
2	Brief description of the e-clean² particle separator	24
2.1	General classification of e-clean ² / technical data	24
2.1.1	Main dimensions with e-clean ²	25
2.1.2	Technical data wood chips with e-clean ² as fuel	26
2.1.3	Emission data wood chips with e-clean ² as fuel	26
2.1.4	Technical data pellets with e-clean ² as fuel	27
2.1.5	Emission data pellets with e-clean ² as fuel	28
3	Brief description of the pellet suction module	29
3.1	General classification of pellet suction module	29

3.2	Main dimensions with pellet suction module.....	30
4	Installation variants and insertion material.....	31
4.1	Delivery options.....	31
4.2	Dimension sheets UTSD240.....	32
4.2.1	UTSD240 with centre pocket.....	32
4.2.2	UTSD240 side ash removal to the rear.....	33
4.2.3	UTSD240 with suction system.....	34
4.2.4	UTSD240 with e-clean and side ash removal to the front.....	35
5	Fuel.....	36
5.1	Permissible fuel.....	36
5.1.1	Wood Chips.....	36
5.1.2	Wood Pellets.....	38
5.1.3	Permitted fuel according to EN303-5, 2012-11-15 edition.....	40
5.1.4	Permissible fuel according to 1st Federal Immission Control Ordinance.....	40
5.2	Other fuels.....	40
5.3	Nominal Heat Output depending on Water Content.....	41
6	Chimney.....	43
6.1	Requirements.....	43
6.2	Design data wood chips as fuel.....	44
6.3	Design data for pellets as fuel.....	45
7	Transportation / Fastening.....	46
7.1	Transportation by crane.....	46
7.2	Transportation by e-clean ² crane.....	47
7.3	Aligning the boiler installation site.....	48
8	Electrics / power supply / external units.....	49
8.1	Regulations.....	49
8.2	Cable Routing.....	49
8.3	Mains connection.....	50
9	Hydraulic requirements.....	51
9.1	Hot water heating systems up to 110°C - diffusion-tight.....	51
9.1.1	Requirements for the filling and top-up water.....	51
9.1.2	Requirements for circulating water.....	51
9.1.3	Water Treatment of Different Raw Waters.....	52

9.2	Thermal discharge safety TAS	53
9.3	Thermally activated extinguishing system	54
9.4	Buffer	55
9.5	Hydraulic Integration.....	57
10	Product data according to regulations (EU) 2015/1187 and 2015/1189	58
10.1	Information on wood chip / pellet firing	58
11	Dismantling, recycling and disposal	63
11.1	General information	63
11.2	Safety Regulations	63
11.3	Recommendation for dismantling of the system or system Components	63

1 Brief description of the UTSD boiler system

1.1 General information

The UTSD series system combines robust construction, mature combustion technology and reliability with the greatest level of comfort, modern design and an innovative control technology.

Through the series automated ignition, integrated burn and performance controls and the available buffer management system, these systems fulfil all of the necessary prerequisites for ecological and economic methods of operation.

The solid, air-cooled and automated rotary grill technology with the furnace chamber constructed of individual parts above it forms the basis for even combustion that produces limited emissions.

1.2 Equipment characteristics and scope of delivery

Wood chip and pellet burner with automatic fuel supply,
Type-tested according to EN303-5:2012
System optionally available in left-hand or right-hand version.

1.2.1 Boiler body

Proven, welded vessel body reinforced with tie rods made of 4-6 mm tested quality steel plate with integrated safety heat exchanger.

1.2.2 Casing

Boiler casing made of powder-coated steel plate, orange (RAL 2000) pre-packed with 60-100 mm of internal insulation.

1.2.3 Combustion technology

Uses a floor combustion feed system with a heat-resistant rotary grill for wood chips and pellets fed by a stoker unit in accordance with EN ISO 17225, biogenic fixed fuels.

Air-control unit for primary and secondary air systems consisting of two servo-motors and two regulated rotary combustion air blowers, regulated rotary suction fan, combustion temperature sensor, mechanical sensors for the furnace area, fill level and fire bed and exhaust temperature sensor, Lambda sensor with protective tube and heat-resistant seals, ignition blower, intake and return sensors.

1.2.4 Combustion chamber

Modular, individually removable combustion chamber lining made of fired, refractory material which partly forms the secondary air duct. The secondary air system will be mounted using a fire-resistant cast iron nozzle.

1.2.5 Standard ash removal system

Consisting of a gear motor, an ash removal screw for the grate and fly ash area, a mobile ash container with a filling volume of 60 l and a locking device on the boiler body.

Grate ash and fly ash are automatically compressed and conveyed into the ash container. Variable cleaning intervals, adjustable according to the fuel.

1.2.6 Cleaning system

The cleaning springs and turbulators in the upright heat exchanger tubes and the cleaning plates in the first heat exchanger pass are moved automatically at the same time as the grate ash removal.

1.2.7 Stoker worm gear unit

Stoker screw housing, stoker screw reinforced in the wear area. Counter bearing, drive motor with torque support.

1.2.8 Safety equipment

- The negative combustion chamber pressure is monitored throughout the entire firing operation and if it falls below a certain value, the fuel supply is stopped and the boiler burns out safely.
- The embers are permanently monitored by a mechanical fuel level system. If the fuel level in the combustion chamber is exceeded, the fuel supply is reduced or stopped.
- The combustion chamber temperature is permanently monitored by a combustion chamber temperature sensor and stops the fuel supply if a certain value is exceeded.
- The boiler is equipped with a safety heat exchanger and a thermal cut-out as well as a safety temperature limiter.
- The fuel feed is equipped with a burn-back protection device (burn-back flap or rotary valve).
- There is a temperature sensor on the stoker unit (fuel feed in front of the combustion chamber) which switches off the firing and empties the stoker if a certain temperature is exceeded.
- Connection option for automatic extinguishing device (SLE) on the stoker unit.

1.2.9 Control unit

Schmid Automatic Control 3 for fully automated full-year operation with practical control panel (7" touch display) for monitoring combustion and automatic fuel detection.

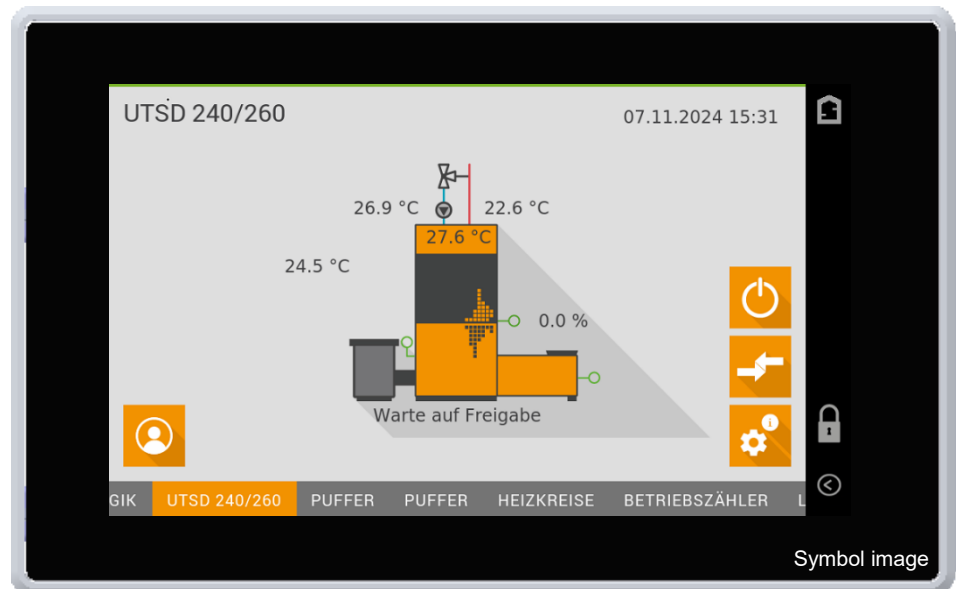

Modes of Operation

There are eight modes of operation available:

Requirement

The heater starts up as soon as a consumer needs energy in the system. The heater is enabled to generate heat until every requirement in the system is satisfied.

According to temperature

The heater starts up as soon as the buffer top sensor falls below the switch-on temperature set. The heater is enabled to generate heat until the buffer bottom sensor exceeds the switch-off temperature set.

Charge level (recommended)

The heater starts up as soon as the charge reached in the buffer falls below the switch-on threshold set. The heater is enabled to generate heat until the buffer charge rate set is reached.

Boiler temperature

The heater is enabled as soon as there is a requirement. The heater is controlled to the boiler temperature set. Depending on the heat consumption, the boiler modulates up to its min. output. Heat generation is enabled until there is no longer any requirement or the boiler temperature exceeds the nominal temperature because the heat consumption is too low. (To ensure clean operation, it is essential to ensure that sufficient heat is removed).

Manual output (only for test operation)

The heater is enabled as soon as there is a requirement. The heater is controlled to the nominal boiler output set. Heat generation is enabled until there is no longer any requirement or the max. boiler temperature is reached because the heat consumption is too low.

Ext. Temp. flow regulator

The boiler setpoint temperature is set via an external specification. Further operating behaviour like “Boiler temperature”

External output

The boiler set output is set via an external specification. Further operating behaviour like “Manual output”

Cascade

The boiler setpoint output and the boiler setpoint temperature are specified via the external cascade controller (DC3).



All of the modes of operation described above can be enabled by an external digital enabling contact (potential free). If this function is not used, a wire jumper must be installed on the AC3 controller at the ST2 Digital IN connector.

Expansions

Individual equipment possibility with motor modules:

- Up to 6 modules on the Automatic Control 3 for different applications.
- Extendible with extension boards with up to 3 motor modules each (can also be installed decentralized, directly at the units)
- Reversing via current measurement for each motor module
- Motor protection function via current measurement (over and undercurrent detection [phase monitoring]) for each motor module
- Low spare parts costs as only the individual module needs to be replaced in the event of a defect and not the expansion board or the Automatic Control 3

Heat distribution via MultiControl3

Interfaces

- Modbus TCP
- Modbus RTU (an adapter from Modbus TCP to Modbus RTU must be provided by the customer)

1.3 General classification of UTSD / technical data

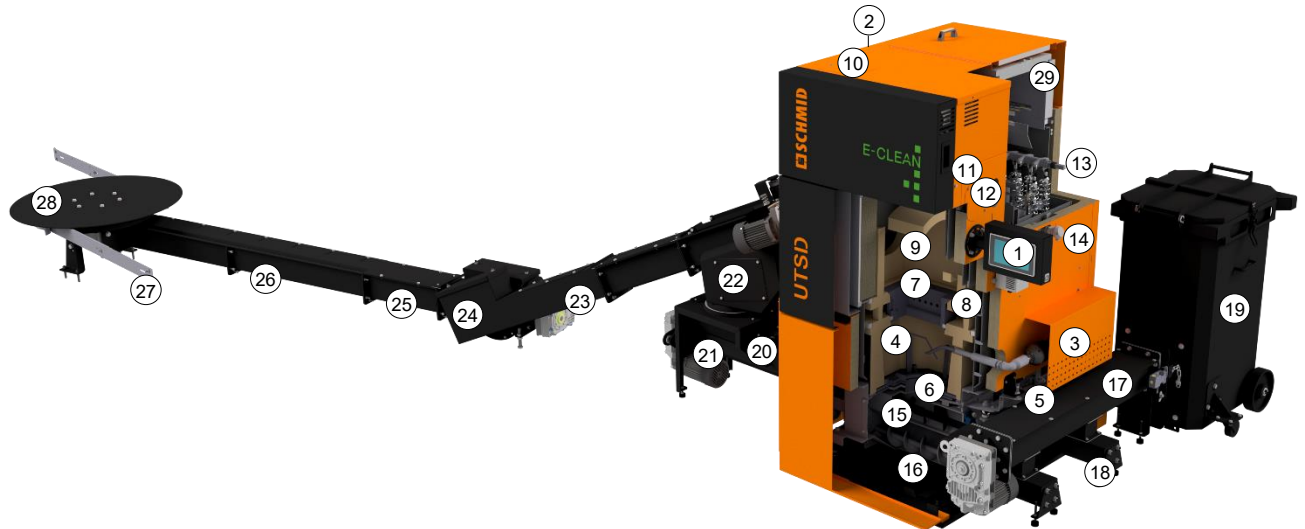

- | | | |
|---|---|---|
| 1. 7" real-glass touch display | 11. Safety heat exchanger | 21. Stoker channel |
| 2. Automatic Control 3 | 12. Immersion sleeve thermal run-off protection | 22. Discharge head with tested burn-back flap |
| 3. ELECTRIC IGNITION | 13. Automatic heat exchanger cleaning | 23. Ascending screw |
| 4. Fuel level sensor | 14. Combustion chamber sensor | 24. Riser screw transfer box |
| 5. Monitoring grate position | 15. Stoker screws | 25. Closed screw channel |
| 6. Rotating grate | 16. Automatic grate ash removal | 26. Open screw channel with inlet plate |
| 7. Secondary air nozzle made of high-quality cast stainless steel | 17. Ash cross screw conveyor | 27. Spring assembly |
| 8. Moulded brick combustion chamber | 18. Automatic heat exchanger de-ashing | 28. Rotary plate |
| 9. Afterburning | 19. Ash bin | 29. E-clean particle separator |
| 10. Negative pressure monitoring | 20. Stoker overtemperature sensor | |

1.3.1 Sectional view UTSD

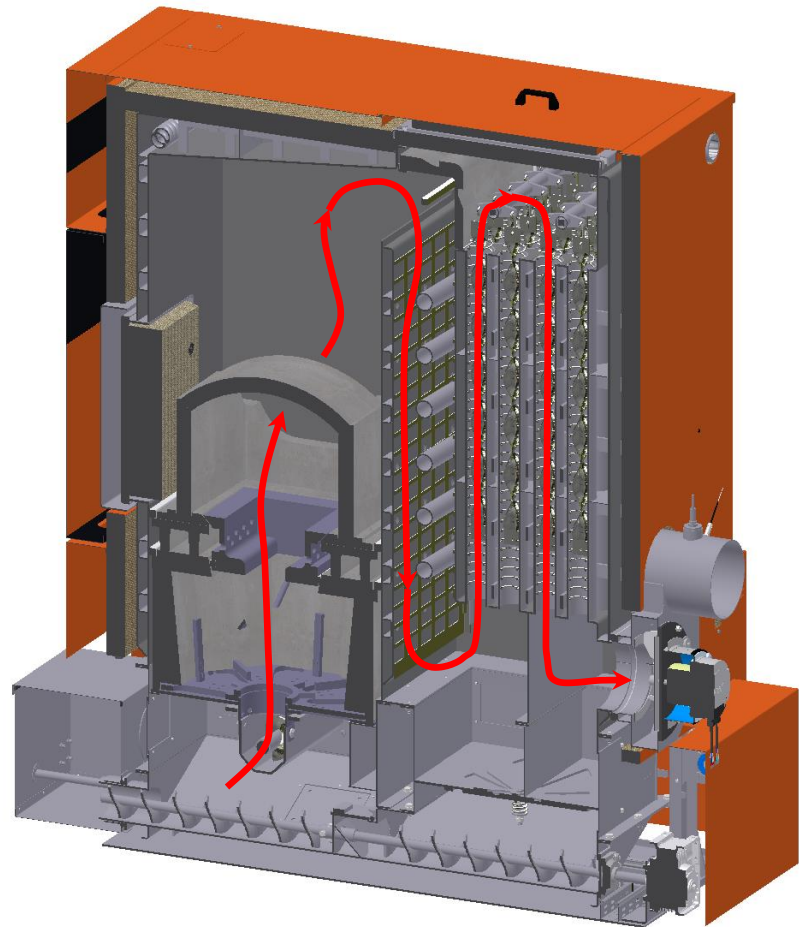

1.3.2 Main dimensions

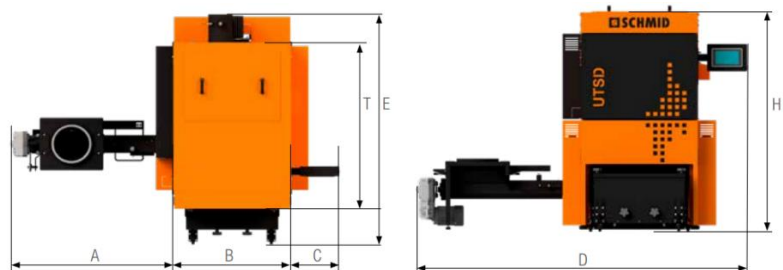

Dimensions of UTSD (mm)	UTSD 240
A Width of stoker connection	1036
B Width of boiler	1060
C Width of display	318
D Width of boiler including stoker connection with display	2409
E Depth of boiler including flue outlet and ash container	1996
T Depth of boiler	1484
H Height of boiler	2014

1.3.3 Technical data in general

UTSD 240 /	Unit	110	115	120	140	145
Available boiler types						
with wood chips as fuel	yes / no	no	no	no	no	yes
with pellets as fuel	yes / no	yes	yes	yes	yes	yes
General boiler data						
Boiler class		5	5	5	5	5
Maximum permissible operating pressure	kPa/bar	300 / 3	300 / 3	300 / 3	300 / 3	300 / 3
Test pressure	kPa/bar	600 / 6	600 / 6	600 / 6	600 / 6	600 / 6
Maximum permissible operating temperature	°C	95	95	95	95	95
Maximum ambient air temperature	°C	65	65	65	65	65
Water valve	Liter	350	350	350	350	350
Boiler weight (without water)	kg	2025	2025	2025	2025	2025
Combustion chamber opening (width/height)	mm	460/460	460/460	460/460	460/460	460/460
Water-side connections						
Flow and return connection (female thread)	Inch	2	2	2	2	2
Drain connection (female thread)	Inch	3/4	3/4	3/4	3/4	3/4
Recommended pipe dimensions	Inch	3	3	3	3	3
Water-side resistance at nominal heat output, 10K	mbar	53.0	57.9	62.8	93.2	99.9
Water-side resistance at nominal heat output, 20K	mbar	13.1	14.9	16.6	23.4	25.2
Flow and return connection (AG) Safety heat exchanger	Inch	1/2	1/2	1/2	1/2	1/2
Therm. drainage safety device min. flow rate	m ³ /h	1.5	1.5	1.5	1.5	1.5
Min. water supply pressure	bar	2	2	2	2	2
Max. water temperature	°C	20	20	20	20	20
Sound emission						
Sound pressure level (at a distance of 0.5 m)	dB(A)	52	52	52	52	52
Sound power level	dB(A)	64	64	64	64	64
Miscellaneous						
Min. free supply air cross-section (VKF heating systems / 24-15)	cm ²	1133	1185	1236	1442	1494
Max. ambient temperature at installation site	°C	35	35	35	35	35

Technical data in general

UTSD 240 /	Unit	150	160	180	200	220
Available boiler types						
with wood chips as fuel	yes / no	yes	yes	yes	yes	yes
with pellets as fuel	yes / no	yes	yes	yes	yes	yes
General boiler data						
Boiler class		5	5	5	5	5
Maximum permissible operating pressure	kPa/bar	300 / 3	300 / 3	300 / 3	300 / 3	300 / 3
Test pressure	kPa/bar	600 / 6	600 / 6	600 / 6	600 / 6	600 / 6
Maximum permissible operating temperature	°C	95	95	95	95	95
Maximum ambient air temperature	°C	65	65	65	65	65
Water valve	Liter	350	350	350	350	350
Boiler weight (without water)	kg	2025	2025	2025	2025	2025
Combustion chamber opening (width/height)	mm	460/460	460/460	460/460	460/460	460/460
Water-side connections						
Flow and return connection (female thread)	Inch	2	2	2	2	2
Drain connection (female thread)	Inch	3/4	3/4	3/4	3/4"	3/4
Recommended pipe dimensions	Inch	3	3	3	3	3
Water-side resistance at nominal heat output, 10K	mbar	106.6	120.1	146.9	173.7	213.2
Water-side resistance at nominal heat output, 20K	mbar	26.9	30.3	37.2	44.1	53.0
Flow and return connection (AG) Safety heat exchanger	Inch	1/2	1/2	1/2	1/2	1/2
Therm. drainage safety device min. flow rate	m ³ /h	1.5	1.5	1.5	1.5	1.5
Min. water supply pressure	bar	2	2	2	2	2
Max. water temperature	°C	20	20	20	20	20
Sound emission						
Sound pressure level (at a distance of 0.5 m)	dB(A)	52	52	52	63	63
Sound power level	dB(A)	64	64	64	76	76
Miscellaneous						
Min. free supply air cross-section (VKF heating systems / 24-15)	cm ²	1545	1648	1854	2060	2266
Max. ambient temperature at installation site	°C	35	35	35	35	35

Technical data in general

UTSD 240 /	Unit	240	250	260	-	-
Available boiler types						
with wood chips as fuel	yes / no	yes	yes	yes	-	-
with pellets as fuel	yes / no	yes	yes	yes	-	-
General boiler data						
Boiler class		5	5	5	-	-
Maximum permissible operating pressure	kPa/bar	300 / 3	300 / 3	300 / 3	-	-
Test pressure	kPa/bar	600 / 6	600 / 6	600 / 6	-	-
Maximum permissible operating temperature	°C	95	95	95	-	-
Maximum ambient air temperature	°C	65	65	65	-	-
Water valve	Liter	350	350	350	-	-
Boiler weight (without water)	kg	2025	2025	2025	-	-
Combustion chamber opening (width/height)	mm	460/460	460/460	460/460	-	-
Water-side connections						
Flow and return connection (female thread)	Inch	2	2	2	-	-
Drain connection (female thread)	Inch	3/4	3/4	3/4	-	-
Recommended pipe dimensions	Inch	3	3	3	-	-
Water-side resistance at nominal heat output, 10K	mbar	252.7	289.1	325.4	-	-
Water-side resistance at nominal heat output, 20K	mbar	62.8	68.2	73.5	-	-
Flow and return connection (AG) Safety heat exchanger	Inch	1/2	1/2	1/2	-	-
Therm. drainage safety device min. flow rate	m³/h	1.5	1.5	1.5	-	-
Min. water supply pressure	bar	2	2	2	-	-
Max. water temperature	°C	20	20	20	-	-
Sound emission						
Sound pressure level (at a distance of 0.5 m)	dB(A)	63	69	69	-	-
Sound power level	dB(A)	76	82	82	-	-
Miscellaneous						
Min. free supply air cross-section (VKF heating systems / 24-15)	cm²	2472	2575	2678	-	-
Max. ambient temperature at installation site	°C	35	35	35	-	-

1.3.4 Technical data for wood chips as fuel

UTSD 240 /	Unit	145	150	160	180	200
------------	------	-----	-----	-----	-----	-----

Performance data

Nominal heat output	kW	145.2	150	160	180	200
Partial load (30% of the nominal heat output)	kW	43.6	45.0	48.0	54.0	60.0
Smallest output	kW	43.1	43.1	43.1	43.1	43.1
Boiler efficiency at nominal heat output	%	92.5	92.5	92.6	92.7	92.8
Boiler efficiency at partial load (30% of nominal heat output)	%	95.0	95.0	94.9	94.7	94.6
Firing capacity at nominal heat output	kW	156.9	162	172.7	194.0	215.3
Firing capacity at partial load (30% of the nominal heat output)	kW	45.4	47.5	50.8	57.3	63.9

Electrical output data

Nominal voltage	AC V	3x400	3x400	3x400	3x400	3x400
Frequency	Hz	50	50	50	50	50
Nominal current	A	20	20	20	20	20
Nominal output :	kW	2.2	2.2	2.2	2.2	2.2
Stand-by output	W	14.1	14.1	14.1	14.1	14.1
* Required electrical auxiliary energy at nominal heat output	W	434	439	449	471	492
* Required electrical auxiliary energy at partial load (30% of the nominal heat output)	W	284	287	291	300	309
* Required electrical auxiliary energy at smallest output	W	284	284	284	284	284

* Auxiliary energy, excluding return flow lifting and fuel transport

UTSD 240 /	Unit	220	240	250	260	-
------------	------	-----	-----	-----	-----	---

Performance data

Nominal heat output	kW	220	240	250	259.3	-
Partial load (30% of the nominal heat output)	kW	66.0	72.0	75.0	78.0	-
Smallest output	kW	43.1	43.1	43.1	43.1	-
Boiler efficiency at nominal heat output	%	93.0	93.1	93.1	93.2	-
Boiler efficiency at partial load (30% of nominal heat output)	%	94.4	94.3	94.2	94.1	-
Firing capacity at nominal heat output	kW	236.5	257.8	268.5	278.4	-
Firing capacity at partial load (30% of the nominal heat output)	kW	70.4	77.0	80.3	83.5	-

Electrical output data

Nominal voltage	AC V	3x400	3x400	3x400	3x400	-
Frequency	Hz	50	50	50	50	-
Nominal current	A	20	20	20	20	-
Nominal output :	kW	2.2	2.2	2.2	2.2	-
Stand-by output	W	14.1	14.1	14.1	14.1	-
* Required electrical auxiliary energy at nominal heat output	W	513	535	545	555	-
* Required electrical auxiliary energy at partial load (30% of the nominal heat output)	W	317	326	331	335	-
* Required electrical auxiliary energy at smallest output	W	284	284	284	284	-

* Auxiliary energy, excluding return flow lifting and fuel transport

1.3.5 Emission data for wood chips as fuel

(data according to test report EN303-5)

UTSD 240 /	Unit	145	150	160	180	200
------------	------	-----	-----	-----	-----	-----

Emission: CO readings

	Unit	145	150	160	180	200
CO	mg/MJ	8	8	8	8	7
CO @ 6% O ₂	mg/m ³	18	17	17	16	15
CO @ 10% O ₂	mg/m ³	13	13	12	12	11
CO @ 11% O ₂	mg/m ³	12	12	11	11	10
CO @ 13% O ₂	mg/m ³	9	9	9	9	8
CO at smallest output	mg/MJ	6	6	6	6	6
CO @ 6% O ₂ at smallest output	mg/m ³	13	13	13	13	13
CO @ 10% O ₂ at smallest output	mg/m ³	10	10	10	10	10
CO @ 11% O ₂ at smallest output	mg/m ³	9	9	9	9	9
CO @ 13% O ₂ at smallest output	mg/m ³	7	7	7	7	7

Emission: NO_x readings

	Unit	145	150	160	180	200
NO _x	mg/MJ	67	67	69	72	75
NO _x @ 6% O ₂	mg/m ³	141	143	146	153	159
NO _x @ 10% O ₂	mg/m ³	104	105	107	112	117
NO _x @ 11% O ₂	mg/m ³	94	95	97	102	106
NO _x @ 13% O ₂	mg/m ³	75	76	78	81	85
NO _x at smallest output	mg/MJ	82	82	82	82	82
NO _x @ 6% O ₂ at smallest output	mg/m ³	174	174	174	174	174
NO _x @ 10% O ₂ at smallest output	mg/m ³	127	127	127	127	127
NO _x @ 11% O ₂ at smallest output	mg/m ³	116	116	116	116	116
NO _x @ 13% O ₂ at smallest output	mg/m ³	93	93	93	93	93

Emission: OGC readings

	Unit	145	150	160	180	200
OGC	mg/MJ	<1	<1	<1	<1	<1
OGC @ 6% O ₂	mg/m ³	2	2	2	1	1
OGC @ 10% O ₂	mg/m ³	1	1	1	1	1
OGC @ 11% O ₂	mg/m ³	1	1	1	1	<1
OGC @ 13% O ₂	mg/m ³	<1	<1	<1	<1	<1
OGC at smallest output	mg/MJ	2	2	2	2	2
OGC @ 6% O ₂ at smallest output	mg/m ³	3	3	3	3	3
OGC @ 10% O ₂ at smallest output	mg/m ³	2	2	2	2	2
OGC @ 11% O ₂ at smallest output	mg/m ³	2	2	2	2	2
OGC @ 13% O ₂ at smallest output	mg/m ³	2	2	2	2	2

Emission: Dust readings

	Unit	145	150	160	180	200
Dust	mg/MJ	5	5	5	6	6
Dust @ 6% O ₂	mg/m ³	10	10	11	12	12
Dust @ 10% O ₂	mg/m ³	7	7	8	8	9
Dust @ 11% O ₂	mg/m ³	7	7	7	8	8
Dust @ 13% O ₂	mg/m ³	5	5	5	6	6
Dust at smallest output	mg/MJ	6	6	6	6	6
Dust @ 6% O ₂ at smallest output	mg/m ³	10	10	10	10	10
Dust @ 10% O ₂ at smallest output	mg/m ³	8	8	8	8	8
Dust @ 11% O ₂ at smallest output	mg/m ³	7	7	7	7	7
Dust @ 13% O ₂ at smallest output	mg/m ³	6	6	6	6	6

Wood chip and pellet firing

UTSD 240

Emission data for wood chips as fuel (data according to test report EN303-5)

UTSD 240 /	Unit	220	240	250	260	-
Emission: CO readings						
CO	mg/MJ	7	7	6	6	-
CO @ 6% O ₂	mg/m ³	15	14	13	13	-
CO @ 10% O ₂	mg/m ³	11	10	10	10	-
CO @ 11% O ₂	mg/m ³	10	9	9	9	-
CO @ 13% O ₂	mg/m ³	8	7	7	7	-
CO at smallest output	mg/MJ	6	6	6	6	-
CO @ 6% O ₂ at smallest output	mg/m ³	13	13	13	13	-
CO @ 10% O ₂ at smallest output	mg/m ³	10	10	10	10	-
CO @ 11% O ₂ at smallest output	mg/m ³	9	9	9	9	-
CO @ 13% O ₂ at smallest output	mg/m ³	7	7	7	7	-
Emission: NO_x readings						
NO _x	mg/MJ	78	81	82	84	-
NO _x @ 6% O ₂	mg/m ³	165	172	175	178	-
NO _x @ 10% O ₂	mg/m ³	121	126	128	131	-
NO _x @ 11% O ₂	mg/m ³	110	115	117	119	-
NO _x @ 13% O ₂	mg/m ³	88	92	93	95	-
NO _x at smallest output	mg/MJ	82	82	82	82	-
NO _x @ 6% O ₂ at smallest output	mg/m ³	174	174	174	174	-
NO _x @ 10% O ₂ at smallest output	mg/m ³	127	127	127	127	-
NO _x @ 11% O ₂ at smallest output	mg/m ³	116	116	116	116	-
NO _x @ 13% O ₂ at smallest output	mg/m ³	93	93	93	93	-
Emission: OGC readings						
OGC	mg/MJ	<1	<1	<1	<1	-
OGC @ 6% O ₂	mg/m ³	1	1	1	1	-
OGC @ 10% O ₂	mg/m ³	1	1	1	<1	-
OGC @ 11% O ₂	mg/m ³	<1	<1	<1	<1	-
OGC @ 13% O ₂	mg/m ³	<1	<1	<1	<1	-
OGC at smallest output	mg/MJ	2	2	2	2	-
OGC @ 6% O ₂ at smallest output	mg/m ³	3	3	3	3	-
OGC @ 10% O ₂ at smallest output	mg/m ³	2	2	2	2	-
OGC @ 11% O ₂ at smallest output	mg/m ³	2	2	2	2	-
OGC @ 13% O ₂ at smallest output	mg/m ³	2	2	2	2	-
Emission: Dust readings						
Dust	mg/MJ	6	7	7	7	-
Dust @ 6% O ₂	mg/m ³	13	14	15	15	-
Dust @ 10% O ₂	mg/m ³	10	10	11	11	-
Dust @ 11% O ₂	mg/m ³	9	10	10	10	-
Dust @ 13% O ₂	mg/m ³	7	8	8	8	-
Dust at smallest output	mg/MJ	6	6	6	6	-
Dust @ 6% O ₂ at smallest output	mg/m ³	10	10	10	10	-
Dust @ 10% O ₂ at smallest output	mg/m ³	8	8	8	8	-
Dust @ 11% O ₂ at smallest output	mg/m ³	7	7	7	7	-
Dust @ 13% O ₂ at smallest output	mg/m ³	6	6	6	6	-

1.3.6 Technical data for pellets as fuel

UTSD 240 /	Unit	110	115	120	140	145
------------	------	-----	-----	-----	-----	-----

Performance data

Nominal heat output	kW	112	115	120	140	145
Partial load (30% of the nominal heat output)	kW	32.2	34.5	36.0	42.0	43.5
Smallest output	kW	32.2	32.2	32.2	32.2	32.2
Boiler efficiency at nominal heat output	%	95.6	95.6	95.6	95.6	95.6
Boiler efficiency at partial load (30% of nominal heat output)	%	97.2	97.2	97.1	97.0	97.0
Firing capacity at nominal heat output	kW	117.2	120.3	125.5	146.4	151.7
Firing capacity at partial load (30% of the nominal heat output)	kW	33.1	35.5	37.1	43.4	45.0

Electrical output data

Nominal voltage	AC V	3x400	3x400	3x400	3x400	3x400
Frequency	Hz	50	50	50	50	50
Nominal current	A	20	20	20	20	20
Nominal output :	kW	2.2	2.2	2.2	2.2	2.2
Stand-by output	W	14.1	14.1	14.1	14.1	14.1
* Required electrical auxiliary energy at nominal heat output	W	265	267	269	280	283
* Required electrical auxiliary energy at partial load (30% of the nominal heat output)	W	206	208	209	213	215
* Required electrical auxiliary energy at smallest output	W	206	206	206	206	206

* Auxiliary energy, excluding return flow lifting and fuel transport

UTSD 240 /	Unit	150	160	180	200	220
------------	------	-----	-----	-----	-----	-----

Performance data

Nominal heat output	kW	150	160	180	196.8	220
Partial load (30% of the nominal heat output)	kW	45.0	48.0	54.0	60.0	66.0
Smallest output	kW	32.2	32.2	32.2	32.2	32.2
Boiler efficiency at nominal heat output	%	95.6	95.6	95.6	95.6	95.0
Boiler efficiency at partial load (30% of nominal heat output)	%	96.9	96.9	96.8	96.6	96.5
Firing capacity at nominal heat output	kW	156.9	167.3	188.2	205.8	231.9
Firing capacity at partial load (30% of the nominal heat output)	kW	46.6	49.7	56.1	62.4	68.7

Electrical output data

Nominal voltage	AC V	3x400	3x400	3x400	3x400	3x400
Frequency	Hz	50	50	50	50	50
Nominal current	A	20	20	20	20	20
Nominal output :	kW	2.2	2.2	2.2	2.2	2.2
Stand-by output	W	14.1	14.1	14.1	14.1	14.1
* Required electrical auxiliary energy at nominal heat output	W	285	291	302	311	361
* Required electrical auxiliary energy at partial load (30% of the nominal heat output)	W	216	218	222	227	231
* Required electrical auxiliary energy at smallest output	W	206	206	206	206	206

* Auxiliary energy, excluding return flow lifting and fuel transport

Technical data for pellets as fuel

UTSD 240 /	Unit	240	250	260	-	-
------------	------	-----	-----	-----	---	---

Performance data

Nominal heat output	kW	240	250	255.2	-	-
Partial load (30% of the nominal heat output)	kW	72.0	75.0	78.0	-	-
Smallest output	kW	32.2	32.2	32.2	-	-
Boiler efficiency at nominal heat output	%	94.4	94.1	94.0	-	-
Boiler efficiency at partial load (30% of nominal heat output)	%	96.4	96.3	96.3	-	-
Firing capacity at nominal heat output	kW	254.4	265.7	271.5	-	-
Firing capacity at partial load (30% of the nominal heat output)	kW	75.0	78.2	81.3	-	-

Electrical output data

Nominal voltage	AC V	3x400	3x400	3x400	-	-
Frequency	Hz	50	50	50	-	-
Nominal current	A	20	20	20	-	-
Nominal output :	kW	2.2	2.2	2.2	-	-
Stand-by output	W	14.1	14.1	14.1	-	-
* Required electrical auxiliary energy at nominal heat output	W	405	427	438	-	-
* Required electrical auxiliary energy at partial load (30% of the nominal heat output)	W	236	238	240	-	-
* Required electrical auxiliary energy at smallest output	W	206	206	206	-	-

* Auxiliary energy, excluding return flow lifting and fuel transport

1.3.7 Emission data for pellets as fuel

(data according to test report EN303-5)

UTSD 240 /	Unit	110	115	120	140	145
------------	------	-----	-----	-----	-----	-----

Emission: CO readings

	Unit	110	115	120	140	145
CO	mg/MJ	3	3	3	2	2
CO @ 6% O ₂	mg/m ³	10	8	9	7	7
CO @ 10% O ₂	mg/m ³	7	7	7	5	5
CO @ 11% O ₂	mg/m ³	6	6	6	5	5
CO @ 13% O ₂	mg/m ³	5	5	5	4	4
CO at smallest output	mg/MJ	9	9	9	9	9
CO @ 6% O ₂ at smallest output	mg/m ³	25	25	25	25	25
CO @ 10% O ₂ at smallest output	mg/m ³	19	19	19	19	19
CO @ 11% O ₂ at smallest output	mg/m ³	17	17	17	17	17
CO @ 13% O ₂ at smallest output	mg/m ³	14	14	14	14	14

Emission: NO_x readings

	Unit	110	115	120	140	145
NO _x	mg/MJ	59	59	60	61	62
NO _x @ 6% O ₂	mg/m ³	177	177	179	184	185
NO _x @ 10% O ₂	mg/m ³	130	130	131	135	136
NO _x @ 11% O ₂	mg/m ³	118	118	119	122	123
NO _x @ 13% O ₂	mg/m ³	94	95	95	98	99
NO _x at smallest output	mg/MJ	50	50	50	50	50
NO _x @ 6% O ₂ at smallest output	mg/m ³	148	148	148	148	148
NO _x @ 10% O ₂ at smallest output	mg/m ³	109	109	109	109	109
NO _x @ 11% O ₂ at smallest output	mg/m ³	99	99	99	99	99
NO _x @ 13% O ₂ at smallest output	mg/m ³	79	79	79	79	79

Emission: OGC readings

	Unit	110	115	120	140	145
OGC	mg/MJ	<1	<1	<1	<1	<1
OGC @ 6% O ₂	mg/m ³	1	1	1	1	1
OGC @ 10% O ₂	mg/m ³	1	1	1	<1	<1
OGC @ 11% O ₂	mg/m ³	<1	<1	<1	<1	<1
OGC @ 13% O ₂	mg/m ³	<1	<1	<1	<1	<1
OGC at smallest output	mg/MJ	1	1	1	1	1
OGC @ 6% O ₂ at smallest output	mg/m ³	3	3	3	3	3
OGC @ 10% O ₂ at smallest output	mg/m ³	2	2	2	2	2
OGC @ 11% O ₂ at smallest output	mg/m ³	2	2	2	2	2
OGC @ 13% O ₂ at smallest output	mg/m ³	2	2	2	2	2

Emission: Dust readings

	Unit	110	115	120	140	145
Dust	mg/MJ	2	2	2	2	2
Dust @ 6% O ₂	mg/m ³	7	7	7	7	7
Dust @ 10% O ₂	mg/m ³	5	5	5	5	5
Dust @ 11% O ₂	mg/m ³	5	5	5	5	5
Dust @ 13% O ₂	mg/m ³	4	4	4	4	4
Dust at smallest output	mg/MJ	3	3	3	3	3
Dust @ 6% O ₂ at smallest output	mg/m ³	8	8	8	8	8
Dust @ 10% O ₂ at smallest output	mg/m ³	6	6	6	6	6
Dust @ 11% O ₂ at smallest output	mg/m ³	6	6	6	6	6
Dust @ 13% O ₂ at smallest output	mg/m ³	4	4	4	4	4

Wood chip and pellet firing

UTSD 240

Emission data for pellets as fuel (data according to test report EN303-5)

UTSD 240 /	Unit	150	160	180	200	220
Emission: CO readings						
CO	mg/MJ	2	2	1	<1	<1
CO @ 6% O ₂	mg/m ³	7	6	4	3	3
CO @ 10% O ₂	mg/m ³	5	4	3	2	2
CO @ 11% O ₂	mg/m ³	4	4	3	2	2
CO @ 13% O ₂	mg/m ³	4	3	2	2	2
CO at smallest output	mg/MJ	9	9	9	9	9
CO @ 6% O ₂ at smallest output	mg/m ³	25	25	25	25	25
CO @ 10% O ₂ at smallest output	mg/m ³	19	19	19	19	19
CO @ 11% O ₂ at smallest output	mg/m ³	17	17	17	17	17
CO @ 13% O ₂ at smallest output	mg/m ³	14	14	14	14	14
Emission: NO_x readings						
NO _x	mg/MJ	62	63	65	66	67
NO _x @ 6% O ₂	mg/m ³	186	188	193	198	201
NO _x @ 10% O ₂	mg/m ³	136	138	142	145	147
NO _x @ 11% O ₂	mg/m ³	124	126	129	132	134
NO _x @ 13% O ₂	mg/m ³	99	101	103	105	107
NO _x at smallest output	mg/MJ	50	50	50	50	50
NO _x @ 6% O ₂ at smallest output	mg/m ³	148	148	148	148	148
NO _x @ 10% O ₂ at smallest output	mg/m ³	109	109	109	109	109
NO _x @ 11% O ₂ at smallest output	mg/m ³	99	99	99	99	99
NO _x @ 13% O ₂ at smallest output	mg/m ³	79	79	79	79	79
Emission: OGC readings						
OGC	mg/MJ	<1	<1	<1	<1	<1
OGC @ 6% O ₂	mg/m ³	1	1	1	1	1
OGC @ 10% O ₂	mg/m ³	<1	<1	<1	<1	<1
OGC @ 11% O ₂	mg/m ³	<1	<1	<1	<1	<1
OGC @ 13% O ₂	mg/m ³	<1	<1	<1	<1	<1
OGC at smallest output	mg/MJ	1	1	1	1	1
OGC @ 6% O ₂ at smallest output	mg/m ³	3	3	3	3	3
OGC @ 10% O ₂ at smallest output	mg/m ³	2	2	2	2	2
OGC @ 11% O ₂ at smallest output	mg/m ³	2	2	2	2	2
OGC @ 13% O ₂ at smallest output	mg/m ³	2	2	2	2	2
Emission: Dust readings						
Dust	mg/MJ	2	2	2	2	2
Dust @ 6% O ₂	mg/m ³	7	7	7	7	7
Dust @ 10% O ₂	mg/m ³	5	5	5	5	5
Dust @ 11% O ₂	mg/m ³	5	4	4	4	4
Dust @ 13% O ₂	mg/m ³	4	4	4	4	4
Dust at smallest output	mg/MJ	3	3	3	3	3
Dust @ 6% O ₂ at smallest output	mg/m ³	8	8	8	8	8
Dust @ 10% O ₂ at smallest output	mg/m ³	6	6	6	6	6
Dust @ 11% O ₂ at smallest output	mg/m ³	6	6	6	6	6
Dust @ 13% O ₂ at smallest output	mg/m ³	4	4	4	4	4

Wood chip and pellet firing

UTSD 240

Emission data for pellets as fuel (data according to test report EN303-5)

UTSD 240 /	Unit	240	250	260	-	-
------------	------	-----	-----	-----	---	---

Emission: CO readings

CO	mg/MJ	<1	<1	<1	-	-
CO @ 6% O ₂	mg/m ³	3	3	3	-	-
CO @ 10% O ₂	mg/m ³	2	2	2	-	-
CO @ 11% O ₂	mg/m ³	2	2	2	-	-
CO @ 13% O ₂	mg/m ³	1	1	1	-	-
CO at smallest output	mg/MJ	9	9	9	-	-
CO @ 6% O ₂ at smallest output	mg/m ³	25	25	25	-	-
CO @ 10% O ₂ at smallest output	mg/m ³	19	19	19	-	-
CO @ 11% O ₂ at smallest output	mg/m ³	17	17	17	-	-
CO @ 13% O ₂ at smallest output	mg/m ³	14	14	14	-	-

Emission: NO_x readings

NO _x	mg/MJ	68	69	69	-	-
NO _x @ 6% O ₂	mg/m ³	204	205	206	-	-
NO _x @ 10% O ₂	mg/m ³	150	151	151	-	-
NO _x @ 11% O ₂	mg/m ³	136	137	137	-	-
NO _x @ 13% O ₂	mg/m ³	109	110	110	-	-
NO _x at smallest output	mg/MJ	50	50	50	-	-
NO _x @ 6% O ₂ at smallest output	mg/m ³	148	148	148	-	-
NO _x @ 10% O ₂ at smallest output	mg/m ³	109	109	109	-	-
NO _x @ 11% O ₂ at smallest output	mg/m ³	99	99	99	-	-
NO _x @ 13% O ₂ at smallest output	mg/m ³	79	79	79	-	-

Emission: OGC readings

OGC	mg/MJ	<1	<1	<1	-	-
OGC @ 6% O ₂	mg/m ³	<1	<1	<1	-	-
OGC @ 10% O ₂	mg/m ³	<1	<1	<1	-	-
OGC @ 11% O ₂	mg/m ³	<1	<1	<1	-	-
OGC @ 13% O ₂	mg/m ³	<1	<1	<1	-	-
OGC at smallest output	mg/MJ	1	1	1	-	-
OGC @ 6% O ₂ at smallest output	mg/m ³	3	3	3	-	-
OGC @ 10% O ₂ at smallest output	mg/m ³	2	2	2	-	-
OGC @ 11% O ₂ at smallest output	mg/m ³	2	2	2	-	-
OGC @ 13% O ₂ at smallest output	mg/m ³	2	2	2	-	-

Emission: Dust readings

Dust	mg/MJ	2	2	2	-	-
Dust @ 6% O ₂	mg/m ³	7	7	7	-	-
Dust @ 10% O ₂	mg/m ³	5	5	5	-	-
Dust @ 11% O ₂	mg/m ³	5	5	5	-	-
Dust @ 13% O ₂	mg/m ³	4	4	4	-	-
Dust at smallest output	mg/MJ	3	3	3	-	-
Dust @ 6% O ₂ at smallest output	mg/m ³	8	8	8	-	-
Dust @ 10% O ₂ at smallest output	mg/m ³	6	6	6	-	-
Dust @ 11% O ₂ at smallest output	mg/m ³	6	6	6	-	-
Dust @ 13% O ₂ at smallest output	mg/m ³	4	4	4	-	-

2 Brief description of the e-clean² particle separator

The e-clean is integrated directly above the boiler heat exchanger. This means that the flue gases are already cleaned in the hot area. Compared to the usual separators, this has the advantage that condensate formation can be ruled out and thus no high-voltage losses or corrosion damage occurrences. Due to the positioning in the hot area, a filter availability of greater than 90% can be permanently guaranteed. The particles are statically charged via the high-voltage electrodes and are deposited in the second heat exchanger pass. They pass into the ash conveying system by means of automatic boiler cleaning.

2.1 General classification of e-clean² / technical data

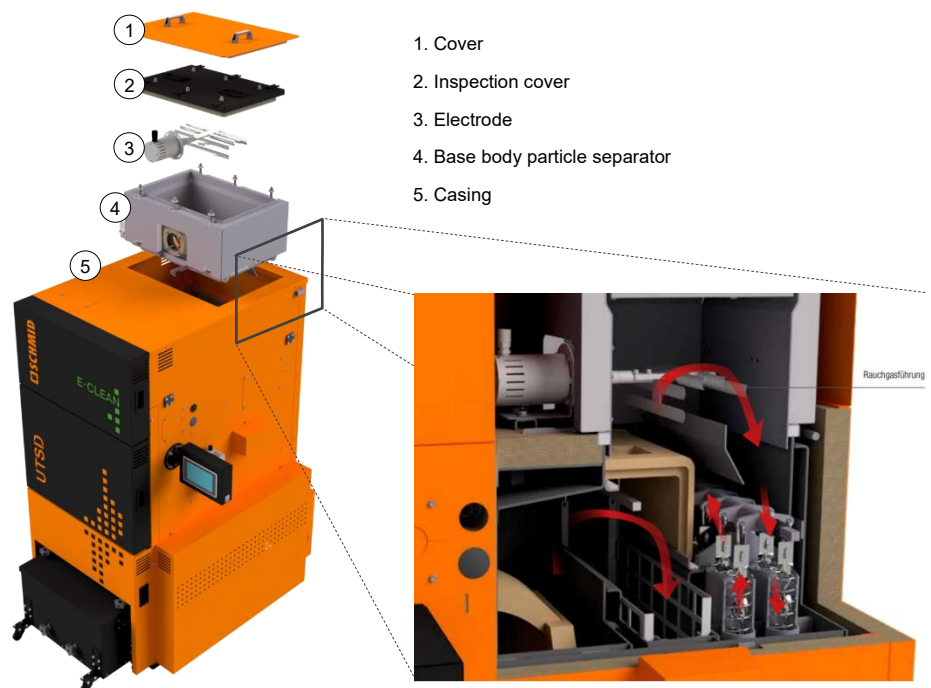

2.1.1 Main dimensions with e-clean²

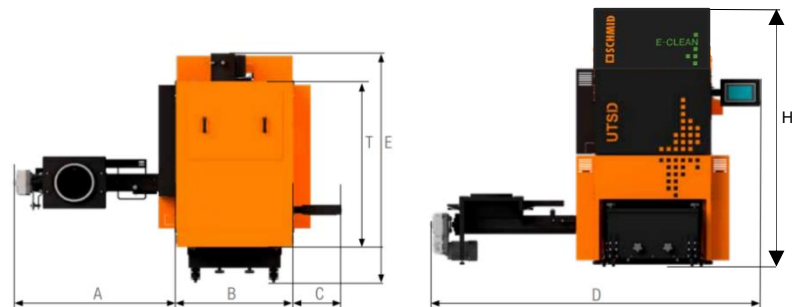

Dimensions of UTSD (mm)	UTSD 240
A Width of stoker connection	1036
B Width of boiler	1060
C Width of display	318
D Width of boiler including stoker connection with display	2414
E Depth of boiler including flue outlet and ash container	1996
T Depth of boiler	1484
H Height of boiler	2245

2.1.2 Technical data wood chips with e-clean² as fuel

UTSD 240 /	Unit	145	150	160	180	200
Electrical output data with e-clean²						
Nominal voltage	AC V	3x400	3x400	3x400	3x400	3x400
Frequency	Hz	50	50	50	50	50
Nominal current	A	20	20	20	20	20
Nominal output :	kW	2.2	2.2	2.2	2.2	2.2
Stand-by output	W	14.1	14.1	14.1	14.1	14.1
Required electrical auxiliary energy at nominal heat output	W	461	466	477	498	520
Required electrical auxiliary energy at partial load (30% of the nominal heat output)	W	305	308	312	321	330
Required electrical auxiliary energy at smallest output	W	305	305	305	305	305

UTSD 240 /	Unit	220	240	250	260	-
Electrical output data with e-clean²						
Nominal voltage	AC V	3x400	3x400	3x400	3x400	-
Frequency	Hz	50	50	50	50	-
Nominal current	A	20	20	20	20	-
Nominal output :	kW	2.2	2.2	2.2	2.2	-
Stand-by output	W	14.1	14.1	14.1	14.1	-
Required electrical auxiliary energy at nominal heat output	W	542	563	574	584	-
Required electrical auxiliary energy at partial load (30% of the nominal heat output)	W	339	348	352	356	-
Required electrical auxiliary energy at smallest output	W	305	305	305	305	-

2.1.3 Emission data wood chips with e-clean² as fuel

(data according to test report EN303-5)

UTSD 240 /	Unit	145	150	160	180	200
Emission: Dust with e-clean²						
Dust	mg/MJ	0.5	0.5	0.6	0.7	1.1
Dust @ 6% O ₂	mg/m ³	1.0	1.0	1.2	1.5	2.3
Dust @ 10% O ₂	mg/m ³	0.7	0.7	0.8	1.0	1.7
Dust @ 11% O ₂	mg/m ³	0.7	0.7	0.8	1.0	1.6
Dust @ 13% O ₂	mg/m ³	0.5	0.5	0.6	0.7	1.2
Dust at smallest output	mg/MJ	0.6	0.6	0.6	0.6	0.6
Dust @ 6% O ₂ at smallest output	mg/m ³	1.0	1.0	1.0	1.0	1.0
Dust @ 10% O ₂ at smallest output	mg/m ³	0.8	0.8	0.8	0.8	0.8
Dust @ 11% O ₂ at smallest output	mg/m ³	0.7	0.7	0.7	0.7	0.7
Dust @ 13% O ₂ at smallest output	mg/m ³	0.6	0.6	0.6	0.6	0.6

UTSD 240 /	Unit	220	240	250	260	-
Emission: Dust with e-clean²						
Dust	mg/MJ	1.2	1.3	1.3	1.4	-
Dust @ 6% O ₂	mg/m ³	2.5	2.7	2.8	2.9	-
Dust @ 10% O ₂	mg/m ³	1.8	2.0	2.0	2.1	-
Dust @ 11% O ₂	mg/m ³	1.7	1.8	1.8	1.9	-
Dust @ 13% O ₂	mg/m ³	1.3	1.4	1.5	1.6	-
Dust at smallest output	mg/MJ	0.6	0.6	0.6	0.6	-
Dust @ 6% O ₂ at smallest output	mg/m ³	1.0	1.0	1.0	1.0	-
Dust @ 10% O ₂ at smallest output	mg/m ³	0.8	0.8	0.8	0.8	-
Dust @ 11% O ₂ at smallest output	mg/m ³	0.7	0.7	0.7	0.7	-
Dust @ 13% O ₂ at smallest output	mg/m ³	0.6	0.6	0.6	0.6	-

2.1.4 Technical data pellets with e-clean² as fuel

UTSD 240 /	Unit	110	115	120	140	145
------------	------	-----	-----	-----	-----	-----

Electrical output data with e-clean²

Nominal voltage	AC V	3x400	3x400	3x400	3x400	3x400
Frequency	Hz	50	50	50	50	50
Nominal current	A	20	20	20	20	20
Nominal output :	kW	2.2	2.2	2.2	2.2	2.2
Stand-by output	W	14.1	14.1	14.1	14.1	14.1
Required electrical auxiliary energy at nominal heat output	W	286	294	297	308	310
Required electrical auxiliary energy at partial load (30% of the nominal heat output)	W	228	235	237	241	242
Required electrical auxiliary energy at smallest output	W	228	228	228	228	228

UTSD 240 /	Unit	150	160	180	200	220
------------	------	-----	-----	-----	-----	-----

Electrical output data with e-clean²

Nominal voltage	AC V	3x400	3x400	3x400	3x400	3x400
Frequency	Hz	50	50	50	50	50
Nominal current	A	20	20	20	20	20
Nominal output :	kW	2.2	2.2	2.2	2.2	2.2
Stand-by output	W	14.1	14.1	14.1	14.1	14.1
Required electrical auxiliary energy at nominal heat output	W	313	319	329	339	390
Required electrical auxiliary energy at partial load (30% of the nominal heat output)	W	243	245	250	254	260
Required electrical auxiliary energy at smallest output	W	228	228	228	228	228

UTSD 240 /	Unit	240	250	260	-	-
------------	------	-----	-----	-----	---	---

Electrical output data with e-clean²

Nominal voltage	AC V	3x400	3x400	3x400	-	-
Frequency	Hz	50	50	50	-	-
Nominal current	A	20	20	20	-	-
Nominal output :	kW	2.2	2.2	2.2	-	-
Stand-by output	W	14.1	14.1	14.1	-	-
Required electrical auxiliary energy at nominal heat output	W	434	455	467	-	-
Required electrical auxiliary energy at partial load (30% of the nominal heat output)	W	264	267	269	-	-
Required electrical auxiliary energy at smallest output	W	228	228	228	-	-

2.1.5 Emission data pellets with e-clean² as fuel

(data according to test report EN303-5)

UTSD 240 /	Unit	110	115	120	140	145
------------	------	-----	-----	-----	-----	-----

Emission: Dust with e-clean²

Dust	mg/MJ	0.2	0.2	0.2	0.3	0.3
Dust @ 6% O ₂	mg/m ³	0.7	0.7	0.7	0.9	0.9
Dust @ 10% O ₂	mg/m ³	0.5	0.5	0.5	0.6	0.7
Dust @ 11% O ₂	mg/m ³	0.5	0.5	0.5	0.6	0.6
Dust @ 13% O ₂	mg/m ³	0.4	0.4	0.4	0.5	0.5
Dust at smallest output	mg/MJ	0.3	0.3	0.3	0.3	0.3
Dust @ 6% O ₂ at smallest output	mg/m ³	0.8	0.8	0.8	0.8	0.8
Dust @ 10% O ₂ at smallest output	mg/m ³	0.6	0.6	0.6	0.6	0.6
Dust @ 11% O ₂ at smallest output	mg/m ³	0.6	0.6	0.6	0.6	0.6
Dust @ 13% O ₂ at smallest output	mg/m ³	0.4	0.4	0.4	0.4	0.4

UTSD 240 /	Unit	150	160	180	200	220
------------	------	-----	-----	-----	-----	-----

Emission: Dust with e-clean²

Dust	mg/MJ	0.3	0.3	0.3	0.4	0.4
Dust @ 6% O ₂	mg/m ³	1.0	1.0	1.2	1.3	1.3
Dust @ 10% O ₂	mg/m ³	0.7	0.7	0.9	0.9	1.0
Dust @ 11% O ₂	mg/m ³	0.6	0.7	0.7	0.8	0.8
Dust @ 13% O ₂	mg/m ³	0.6	0.6	0.7	0.8	0.8
Dust at smallest output	mg/MJ	0.3	0.3	0.3	0.3	0.3
Dust @ 6% O ₂ at smallest output	mg/m ³	0.8	0.8	0.8	0.8	0.8
Dust @ 10% O ₂ at smallest output	mg/m ³	0.6	0.6	0.6	0.6	0.6
Dust @ 11% O ₂ at smallest output	mg/m ³	0.6	0.6	0.6	0.6	0.6
Dust @ 13% O ₂ at smallest output	mg/m ³	0.4	0.4	0.4	0.4	0.4

UTSD 240 /	Unit	240	250	260	-	-
------------	------	-----	-----	-----	---	---

Emission: Dust with e-clean²

Dust	mg/MJ	0.4	0.4	0.4	-	-
Dust @ 6% O ₂	mg/m ³	1.3	1.4	1.4	-	-
Dust @ 10% O ₂	mg/m ³	1.0	1.0	1.0	-	-
Dust @ 11% O ₂	mg/m ³	0.9	1.0	1.0	-	-
Dust @ 13% O ₂	mg/m ³	0.8	0.8	0.8	-	-
Dust at smallest output	mg/MJ	0.3	0.3	0.3	-	-
Dust @ 6% O ₂ at smallest output	mg/m ³	0.8	0.8	0.8	-	-
Dust @ 10% O ₂ at smallest output	mg/m ³	0.6	0.6	0.6	-	-
Dust @ 11% O ₂ at smallest output	mg/m ³	0.6	0.6	0.6	-	-
Dust @ 13% O ₂ at smallest output	mg/m ³	0.4	0.4	0.4	-	-

3 Brief description of the pellet suction module

Fully automatic solution for the convenient conveying of pellets from silos of all types. This system consists of a special storage container, precise fill level sensor, a double rotary valve and a powerful suction turbine that generates the necessary vacuum to convey the pellets. The system operates fully automatically and is controlled via the existing Automatic Control 3 boiler control system.



With the pellet suction module, suction distances of up to 25 m and height differences of up to 4 m can be overcome.

3.1 General classification of pellet suction module

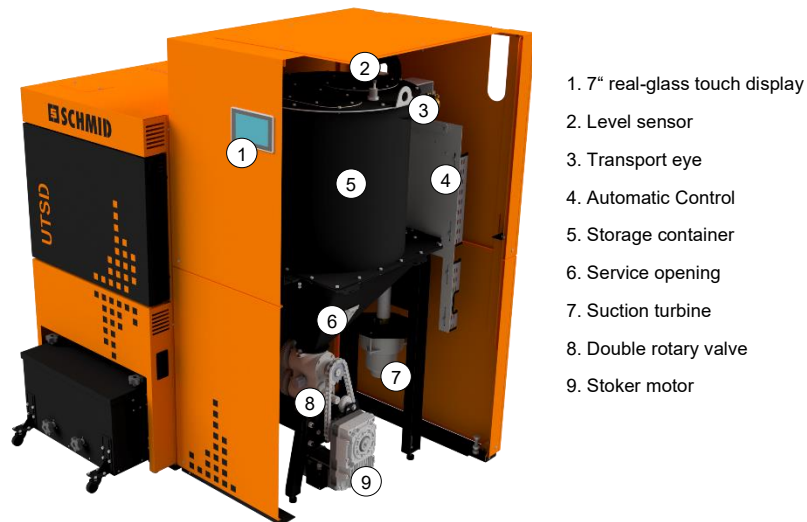

3.2 Main dimensions with pellet suction module

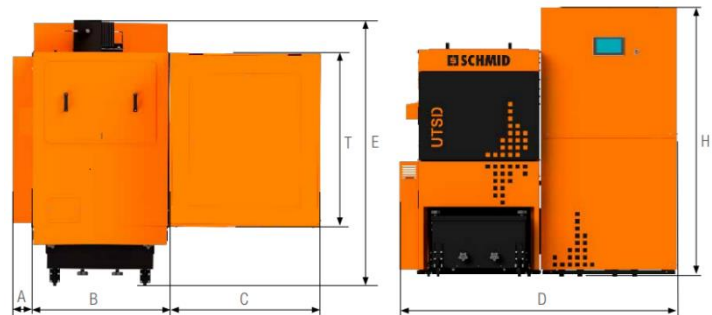

Dimensions of UTSD (mm)	UTSD 240
A Width of service cover	109
B Width of boiler	1060
C Width of suction module	871
D Width of boiler including suction module and service cover	2040
E Deep boiler incl. flue gas connection and ash box	1996
T Depth of suction module	1040
H Height of suction module	1775

4 Installation variants and insertion material

4.1 Delivery options

The boiler is always supplied in an assembled state, excluding stoker and ash removal components.

Example UTSD with centre ash removal:



In the event of adverse insertion situations, it is possible for the boiler to be delivered split. This must be specified when ordering.

Split version (shown as a symbol):

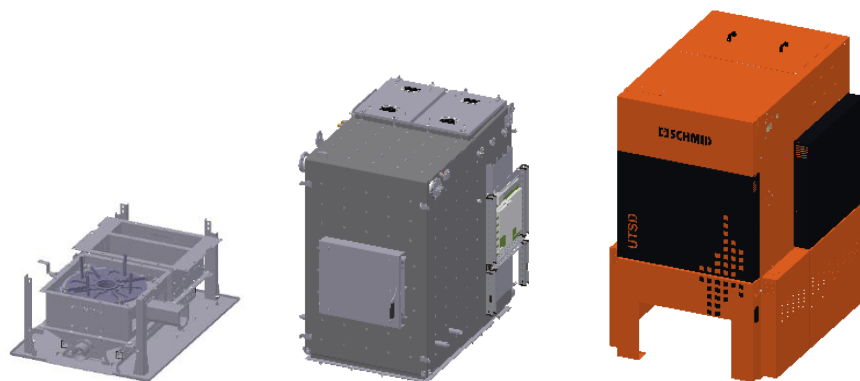

Other components such as drives, combustion chamber stones etc. are packed separately.

4.2 Dimension sheets UTSD240

The following examples show a selection of different boiler variants with the main dimensions, the installation dimensions and the service intervals to be observed.

Further documentation on the different variants and dimension sheets can be requested from Schmid AG.

4.2.1 UTSD240 with centre pocket

Dimensions valid for version
Stoker right and left

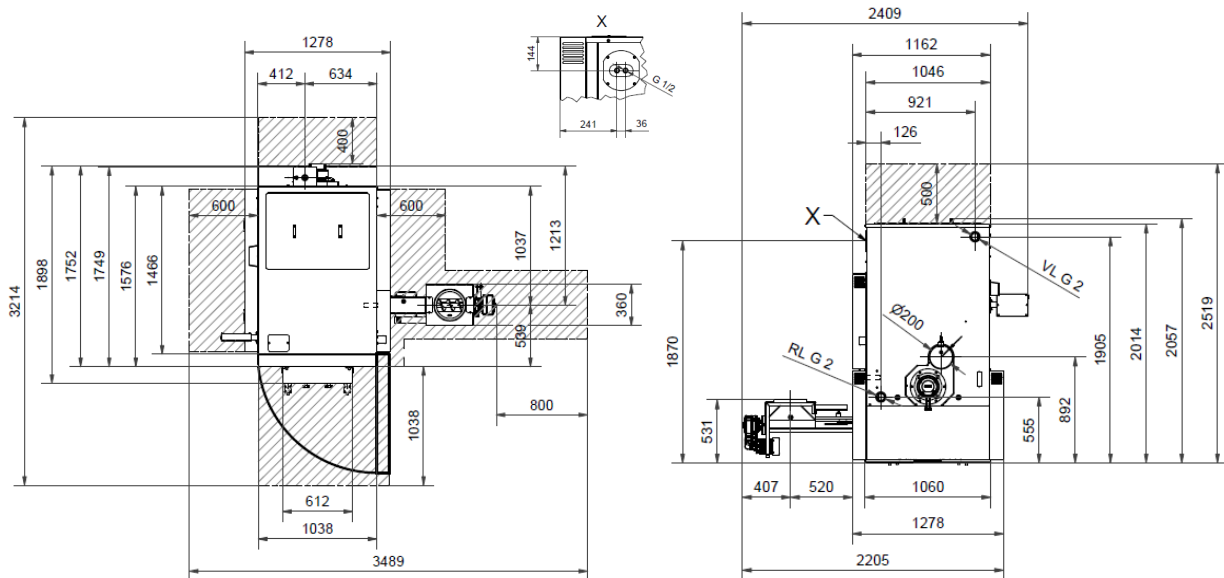

Installation dimensions of unsplit boiler	B	H	T	Gew.
Heat exchanger and boiler base	1084mm	2007mm	1484mm	1791kg
Installation dimensions of split boiler	B	H	T	Gew.
Heat exchanger incl. combustion chamber	1084mm	1548mm	1418mm	1479kg
Boiler base	1060mm	575mm	1484mm	312kg
Total weight of boiler	2025kg			
Minimum room height	2500mm			

4.2.2 UTSD240 side ash removal to the rear

Dimensions valid for version
Collective ash removal right and left

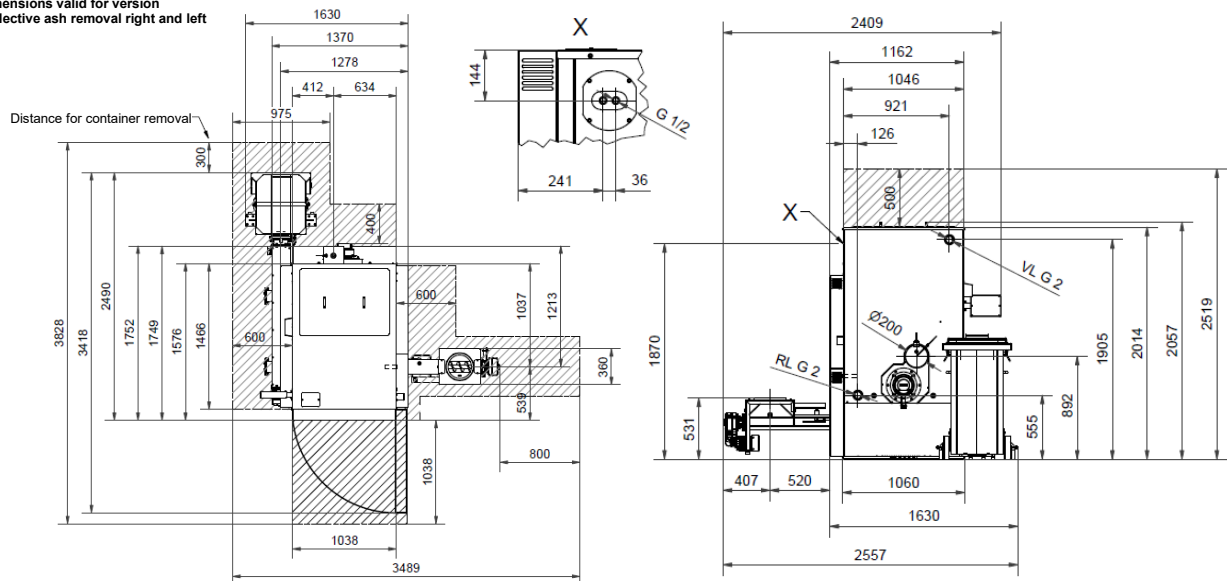

Installation dimensions of unsplit boiler	B	H	T	Gew.
Heat exchanger and boiler base	1084mm	2007mm	1484mm	1791kg
Installation dimensions of split boiler	B	H	T	Gew.
Heat exchanger incl. combustion chamber Boiler base	1084mm 1060mm	1548mm 575mm	1418mm 1484mm	1479kg 312kg
Total weight of boiler				2025kg
Minimum room height				2500mm

Wood chip and pellet firing UTSD 240

4.2.3 UTSD240 with suction system

Dimensions valid for version
Stoker right and left

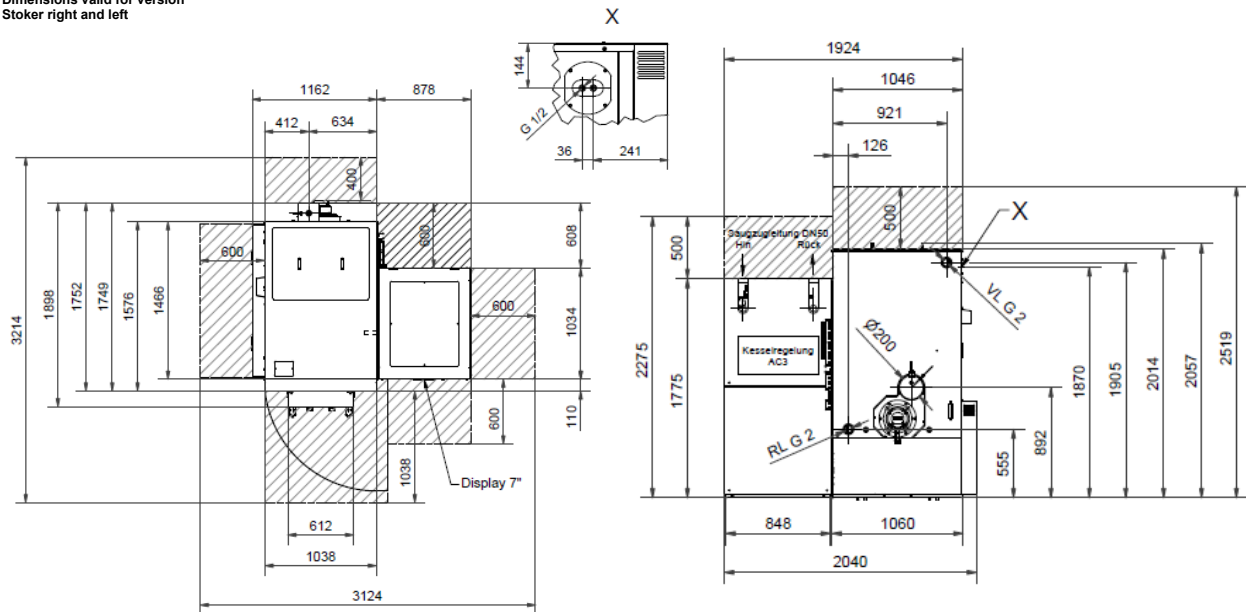

Installation dimensions of unsplit boiler	B	H	T	Gew.
Heat exchanger and boiler base	1084mm	2007mm	1484mm	1791kg
Installation dimensions of split boiler	B	H	T	Gew.
Heat exchanger incl. combustion chamber	1084mm	1548mm	1418mm	1479kg
Boiler base	1060mm	575mm	1484mm	312kg
Installation dimensions of suction system	B	H	T	Gew.
Suction system without casing	1740mm	1693mm	899mm	217kg
Total weight of boiler	2025kg			
Minimum room height	2500mm			

4.2.4 UTSD240 with e-clean and side ash removal to the front

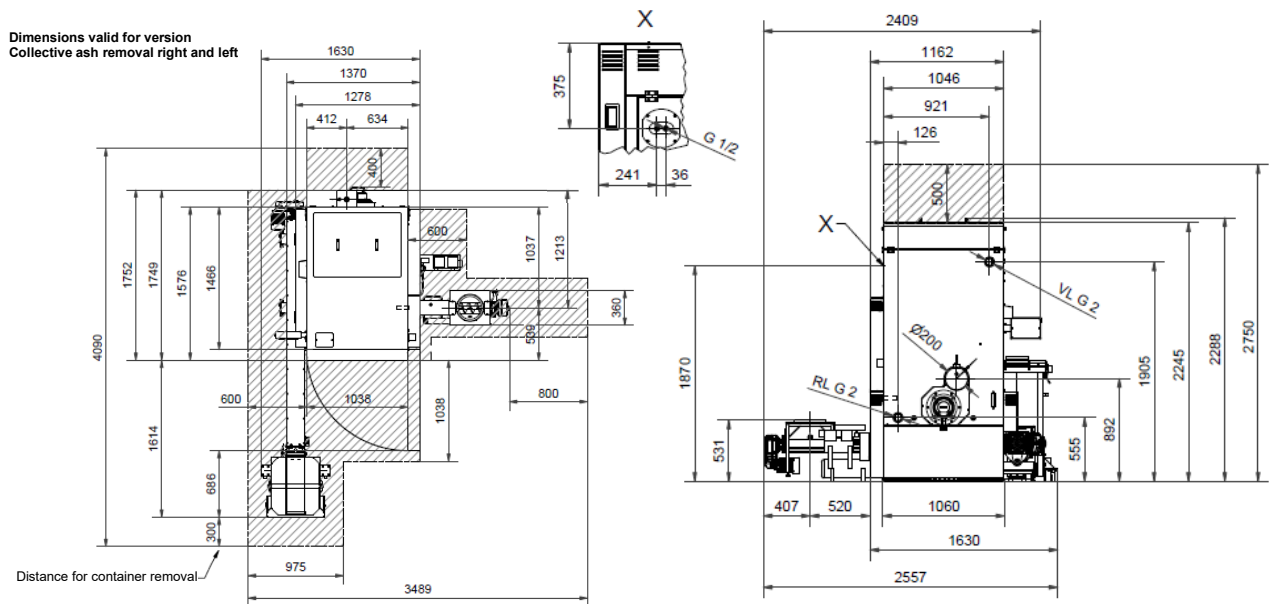

Installation dimensions of unsplit boiler	B	H	T	Gew.
Heat exchanger and boiler base	1084mm	2007mm	1484mm	1791kg
Installation dimensions of split boiler	B	H	T	Gew.
Heat exchanger incl. combustion chamber	1084mm	1548mm	1418mm	1479kg
Boiler base	1060mm	575mm	1484mm	312kg
Total weight of boiler	2025kg			
Optimum room height	2750mm			
Minimum room height	2500mm			

5 Fuel

5.1 Permissible fuel

The UTSD heating system is designed for typical use for the combustion of untreated wood in the form of wood chips, shavings, or wood pellets.



With regard to the quality requirements for solid fuels, DIN EN ISO 17225:2021 “Solid biofuels - Fuel specifications and classes” applies

- Part 4: “Graded wood chips”
- Part 2: “Graded wood pellets”

Following this standard, the properties of the fuels that can be used in the UTSD are specified in more detail below.

5.1.1 Wood Chips

Particle Size

The main criteria for defining the property classes are particle size, water content and ash content of the fuel. Based on DIN EN ISO 17225-4:2021, the particle size for wood chips, among others, is categorised as P45.

P class	Main portion (Mass fraction min. 60%)	Fine fraction (Wt. -%) ≤ 3.15mm	Coarse fraction (Wt. -%) max. length, max. cross-section
P45	3.15mm < P ≤ 45mm	≤ 5%	≤ 10% >63mm, all ≤ 150mm Cross-section of the oversized particles ≤ 6cm ²

Medium wood chips with a particle size of up to 45 mm (P45) are used more in larger systems, but can also be suitable for small systems, depending on the diameter of the screw conveyor. Oversized pieces (end pieces) can cause disturbances in the operation of the plants. A high proportion of fines (dust) can lead to high emissions and the ejection of glowing particles.

For the UTSD, wood chips of category P45, as described above, can be used as fuel. The maximum length of oversized particles is limited to 150 mm.

Particle Size

When selecting the fuel, it is important to consider that the calorific value of the wood primarily depends on the moisture content. The more water the wood contains, the lower the calorific value, as the water evaporates during the combustion process, consuming heat. This results in a reduction in efficiency and thus leads to higher wood consumption. Moreover, as the moisture content of the fuel increases, a further reduction in boiler performance, increased ash production, smoke development, and reduced storage stability can be expected.

The maximum permissible moisture content of the wood chips is 35% (M35). The water content of the wood chips must also not be less than 15% (M15), as a higher aerosol formation here leads to a higher dust value. See the attached table in chapter “Nominal heat output as a function of water content”.

For the technical analysis, a representative calorific value is selected depending on the moisture content. For economical and environmentally friendly combustion, the calorific value should not be less than approximately 4 kWh/kg.

Water content	Moisture	Calorific Value	Relative Wood Consumption
20.0%	25.0%	4.0 kWh/kg	100%
26.0%	35.0%	3.7 kWh/kg	110%
30.0%	42.9%	3.4 kWh/kg	120%

Ash Content

For environmentally friendly operation of the wood chip heating system, a low ash content is required. This simultaneously minimizes the content of combustion-critical elements. Inorganic substances in wood that form aerosols during combustion, such as potassium, chlorine, or sodium, primarily contribute to dust emissions. Such elements are primarily found in the needles, leaves and bark of a tree. Clean, well-prepared pure wood assortments, such as roughly debranched energy roundwood without needles, leaves, and only a small amount of bark, show the lowest levels of combustion-critical elements. They are therefore recommended for use in small combustion systems. Ideally, the ash content should be a maximum of 1.0 % by weight (A1.0).

When using wood chips with a higher ash content (property class A2 or B1/2), the use of secondary measures (filter technology) is usually necessary to comply with the dust emission limits according to the 1st BImSchV [Federal Immission Protection Decrees] (2nd stage). This requires a special written approval from Schmid AG.

5.1.2 Wood Pellets

Wood pellets are cylindrical pellets made from untreated wood chips and sawdust from the wood processing industry, as well as natural forest residue wood. They have a standardised diameter and length. They are pressed under high pressure and have a very low moisture content. The energy content of 2 kg of pellets roughly corresponds to the energy content of one litre of heating oil.

The main criteria for defining the property classes are the length and diameter, water content and ash content of the fuel.

Length and Diameter

The diameter of the pellets used must correspond to D06 for use with the UTSD in connection with the pellet suction system. In connection with another discharge system (e.g., for wood chips), the diameter can also correspond to D08.

- D06

The diameter of the pellets must be 6 mm +/- 1 mm. The length of the pellets must be between 3.15 mm and 40 mm. A maximum of 1.0 wt.-% of the pellets may be up to 45 mm in length.

- D08

The diameter of the pellets must be 8 mm +/- 1 mm. The length of the pellets must be between 3.15 mm and 40 mm. A maximum of 1.0 wt.-% of the pellets may be up to 45 mm in length.

Water content

The water content must be less than 10% (M10) for property class A1.

Ash Content

The ash content for property class A1 is a maximum of 0.7% by weight (A0.7)

Alternatively, pellets with the “ENplus” or “DINplus” certificate are also suitable, as the quality requirements of property class A1 are also met.

5.1.3 Permitted fuel according to EN303-5, 2012-11-15 edition

In accordance with EN303-5, 2012-11-15 edition, the biogenic fuels B1 and C1 may be used in this heating system.

B1 fuel

Wood chips (mechanically shredded wood, usually up to a maximum length of 15 cm), moisture content w from 15% to 35% according to EN 14961-4.

C1 fuel

Pellets (e.g., pellets without binders, made from wood and/or bark particles; natural binders such as molasses, vegetable paraffins, and starch are permitted); pellets according to EN 14961-2.

5.1.4 Permissible fuel according to 1st Federal Immission Control Ordinance

According to §3 (1) 1. Federal Immission Control Ordinance, fuel classes 4 and 5a may be used as fuel in this heating system.

Fuel Class 4

Natural, lumpy wood including adhering bark, for example in the form of wood chips.

Fuel Class 5A

Pellets or wood briquettes made from untreated wood.

5.2 Other fuels

If fuels such as residual wood, carpentry waste or similar that do not correspond to the above list are to be used, this requires special written approval from Schmid AG. See the attached table in chapter "Nominal heat output as a function of water content" column "Fuels with special approval."

5.3 Nominal Heat Output depending on Water Content

The following table shows the maximum nominal heat output as a function of water content in relation to the fuels approved for the UTSD in accordance with DIN EN ISO 17225:2021 “Biogenic solid fuels - Fuel specifications and classes”.

**The table is only valid if the boiler is operated with fixed fuel and primary air quantities.
(no readjustment of the output by the control).**

Please note:



All fuels other than untreated wood as described above are not intended and can lead to damage to the system such as corrosion, mechanical defects and environmental damage (emissions of e.g. heavy metals). It is therefore strictly forbidden to use fuels that are not intended.

The combustion of wood with a high moisture content also causes a reduction in efficiency and a risk of corrosion or tar formation.

Failure to comply with these requirements will invalidate the warranty on system components, machines and emissions.

Basis for energy content of wood chips Austrian Standard M7132 (mixed wood chips 50% spruce, 50% beech)

	Wood Chips M15 A1 P45 F05 L150 A1.0	Wood Chips ≤ M20 A1 P45 F05 L150 A1.0	Wood Chips ≤ M25 A1 P45 F05 L150 A1.0	Wood Chips ≤ M30 A1 P45 F05 L150 A1.0	Wood Chips ≤ M35 A1 P45 F05 L150 A1.0	Pellets M10 A1 D06 A0.7	Fuels with Special Release
	kW	kW	kW	kW	kW	kW	
UTSD 240/110	---	---	---	---	---	112	
UTSD 240/115	---	---	---	---	---	115	
UTSD 240/120	---	---	---	---	---	120	
UTSD 240/140	---	---	---	---	---	140	
UTSD 240/145	145,2	145,2	145,2	134	122	145	145,2
UTSD 240/150	150	150	150	138	126	150	150
UTSD 240/160	160	160	160	147	135	160	160
UTSD 240/180	180	180	180	166	151	180	160
UTSD 240/200	200	200	200	184	168	196,8	160
UTSD 240/220	200	220	220	203	185	220	160
UTSD 240/240	200	240	240	221	202	240	160
UTSD 240/250	200	250	250	230	210	250	160
UTSD 240/260	200	259,3	259,3	240	219	255,2	160

	For wood chips ≤ M15, the boiler output is limited to the specified value in order to avoid excessive wear.
	Maximum approved output to avoid excessive wear. The specified values can be corrected upwards or downwards depending on the fuel properties after special approval has been granted by Schmid AG.

6 Chimney

6.1 Requirements

1. The chimney must be inspected by the responsible chimney sweep before the installation of the boiler.
2. A chimney that complies with regulations and is properly dimensioned for the boiler output according to country-specific norms (e.g., EN 1443, DIN 4705, or SIA 384/4, CH) is a prerequisite for the proper and economical operation of the heating system.
3. Install building code-approved exhaust systems (VKF-certified in Switzerland).
4. The exhaust pipe between the boiler and chimney must be laid tightly and insulated.
5. The exhaust duct should be inserted into the chimney at an angle of at least 30°.

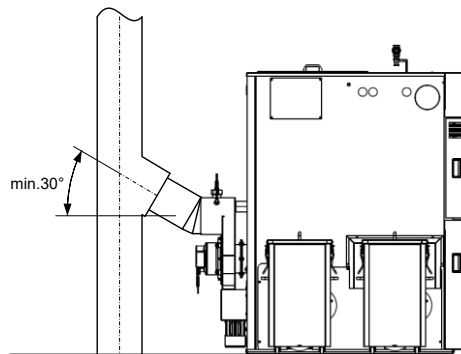

6. Exhaust gas temperature: For boilers operated at nominal heat output with an exhaust gas temperature of less than 160K above room temperature, the exhaust paths (exhaust pipe and chimney) must be moisture-resistant to prevent possible sooting, insufficient draft pressure, and condensation in the exhaust path.
7. The chimney must be integrated into the lightning protection concept prepared by a specialist firm and executed according to country-specific standards (e.g., EN 62305-3).



Installation of a chimney draft regulator or secondary air device is mandatory for chimney systems with over 20 Pa chimney draft. For chimney systems with a chimney draft of less than 20 Pa, no chimney draft regulator or secondary air device is required.

6.2 Design data wood chips as fuel

UTSD 240 /	Unit	145	150	160	180	200
------------	------	-----	-----	-----	-----	-----

Design data for chimney calculation

Flue gas temperature at nominal heat output	°C	122	125	130	135	140
Flue gas temperature at partial load	°C	85	87	89	91	93
Exhaust gas mass flow at nominal heat output	kg/s	0.120	0.123	0.129	0.143	0.155
Exhaust gas mass flow at partial load	kg/s	0.042	0.043	0.045	0.050	0.054
Required delivery pressure	Pa	8	8	8	8	8
Flue pipe connection diameter	mm	200	200	200	200	200
Height centre of flue pipe connection	mm	892	892	892	892	892
CO ₂ content at nominal heat output	%	11.5	11.6	11.7	11.9	12.1
CO ₂ content at partial load	%	9.3	9.3	9.4	9.5	9.7

UTSD 240 /	Unit	220	240	250	260	-
------------	------	-----	-----	-----	-----	---

Design data for chimney calculation

Flue gas temperature at nominal heat output	°C	145	150	155	160	-
Flue gas temperature at partial load	°C	95	97	99	100	-
Exhaust gas mass flow at nominal heat output	kg/s	0.168	0.181	0.187	0.193	-
Exhaust gas mass flow at partial load	kg/s	0.060	0.064	0.066	0.069	-
Required delivery pressure	Pa	8	8	8	8	-
Flue pipe connection diameter	mm	200	200	200	200	-
Height centre of flue pipe connection	mm	892	892	892	892	-
CO ₂ content at nominal heat output	%	12.4	12.6	12.7	12.8	-
CO ₂ content at partial load	%	9.8	9.9	10.0	10.1	-

6.3 Design data for pellets as fuel

UTSD 240 /	Unit	110	115	120	140	145
------------	------	-----	-----	-----	-----	-----

Design data for chimney calculation

Flue gas temperature at nominal heat output	°C	105	107	110	120	122
Flue gas temperature at partial load	°C	80	81	82	84	85
Exhaust gas mass flow at nominal heat output	kg/s	0.072	0.073	0.075	0.085	0.087
Exhaust gas mass flow at partial load	kg/s	0.016	0.017	0.019	0.023	0.024
Required delivery pressure	Pa	8	8	8	8	8
Flue pipe connection diameter	mm	200	200	200	200	200
Height center of flue pipe connection	mm	892	892	892	892	892
CO ₂ content at nominal heat output	%	11.4	11.5	11.6	11.9	12
CO ₂ content at partial load	%	14.7	14.6	14.5	14.3	14.2

UTSD 240 /	Unit	150	160	180	200	220
------------	------	-----	-----	-----	-----	-----

Design data for chimney calculation

Flue gas temperature at nominal heat output	°C	125	130	135	140	145
Flue gas temperature at partial load	°C	87	89	91	93	95
Exhaust gas mass flow at nominal heat output	kg/s	0.090	0.094	0.103	0.112	0.123
Exhaust gas mass flow at partial load	kg/s	0.025	0.027	0.031	0.036	0.040
Required delivery pressure	Pa	8	8	8	8	8
Flue pipe connection diameter	mm	200	200	200	200	200
Height centre of flue pipe connection	mm	892	892	892	892	892
CO ₂ content at nominal heat output	%	12.1	12.3	12.7	13.0	13.4
CO ₂ content at partial load	%	14.2	14.0	13.8	13.6	13.3

UTSD 240 /	Unit	240	250	260	-	-
------------	------	-----	-----	-----	---	---

Design data for chimney calculation

Flue gas temperature at nominal heat output	°C	150	155	160	-	-
Flue gas temperature at partial load	°C	97	99	100	-	-
Exhaust gas mass flow at nominal heat output	kg/s	0.133	0.138	0.140	-	-
Exhaust gas mass flow at partial load	kg/s	0.044	0.046	0.048	-	-
Required delivery pressure	Pa	8	8	8	-	-
Flue pipe connection diameter	mm	200	200	200	-	-
Height centre of flue pipe connection	mm	892	892	892	-	-
CO ₂ content at nominal heat output	%	13.8	13.8	13.9	-	-
CO ₂ content at partial load	%	13.1	12.9	12.8	-	-

7 Transportation / Fastening



Warning!

Risk from Suspended Loads

If the boiler falls during transport, persons can be seriously injured and the boiler can be damaged. When installing or transporting the boiler, ensure that you move the boiler with a suitable lifting device.

7.1 Transportation by crane

1. Remove the packaging material from the boiler.
2. Remove the heat exchanger access cover (1) from the boiler.
3. Remove the upper casing plate (2).

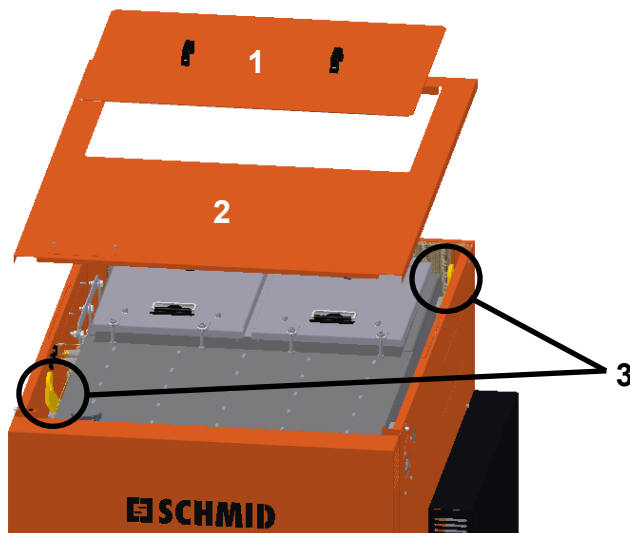

4. There are two crane eyes (3) on the left and right boiler wall. These can be used to attach a transport hook.
5. Carefully lift the boiler and remove the wooden skids and transport timbers.
6. Place the boiler at the planned installation location, observing the minimum clearances.



Caution:

Observe the permissible load capacity of the lifting tools and lifting aids used. The weight of the boiler can be found in the technical data.

7.2 Transportation by e-clean² crane

1. Remove the packaging material from the boiler.
2. Remove the cover (1) on the front of the boiler.
3. Remove the heat exchanger access cover (2) from the boiler.
4. Remove the upper casing plate (3).
5. Fold down the shuttering panels marked in yellow.

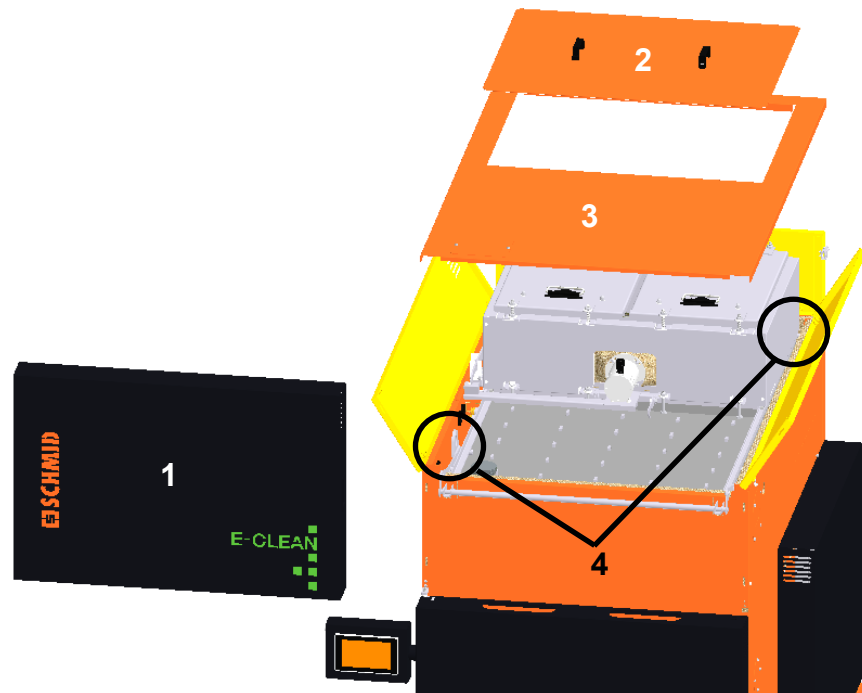

6. There are two crane eyes (4) on the left and right boiler wall. These can be used to attach a transport hook.
7. Carefully lift the boiler and remove the wooden skids and transport timbers.
8. Place the boiler at the planned installation location, observing the minimum clearances.



Caution:

Observe the permissible load capacity of the lifting tools and lifting aids used. The weight of the boiler can be found in the technical data.

7.3 Aligning the boiler installation site

Check whether the boiler is level. If not, you can use the screws on the boiler base to adjust it.



Aligning the boiler so that it is slightly tilted forwards makes it easier to bleed the hydraulic system.

1. Remove the service covers (1) on the left and right side of the boiler. The locking screws must be loosened beforehand.
2. There is a screw (2) at each corner of the boiler base. You can use this to set up the boiler.

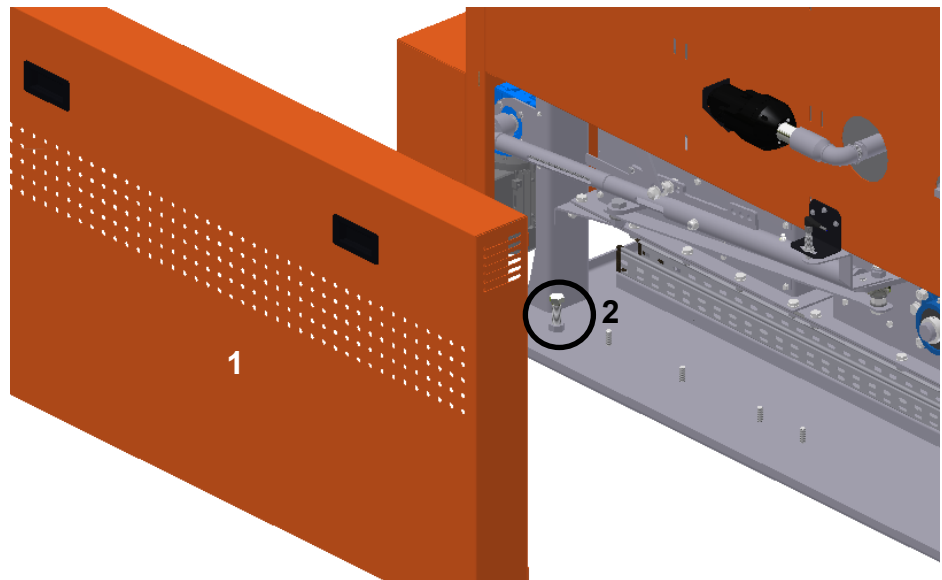

The boiler can be placed on structure-borne sound absorbers to prevent structure-borne sound being transmitted to the object as far as possible. Place these under the screws (2). Please note the load-bearing capacity of the structure-borne sound absorbers, taking into account the weight of the boiler including water.

8 Electrics / power supply / external units

8.1 Regulations

When connecting the system electrically, the provisions of 2014/35/EU (Low Voltage Directive) must be observed. The electrical connection must be made to a separate, all-pole isolation device with a minimum contact spacing of 3 mm. There should be no electrical installations such as sockets, distribution boxes, light bulbs, or light switches in the fuel storage room. Lighting fixtures must be explosion-proof. The VDE regulations for dust hazardous areas must be observed.

8.2 Cable Routing

The control unit is integrated in the side wall of the boiler. The mains supply cable and cables from external units are fed through the rear wall of the boiler and must be routed as shown in the following figure. The cables must be relieved of strain at the cable ducts and at the lugs provided for this purpose using cable ties.

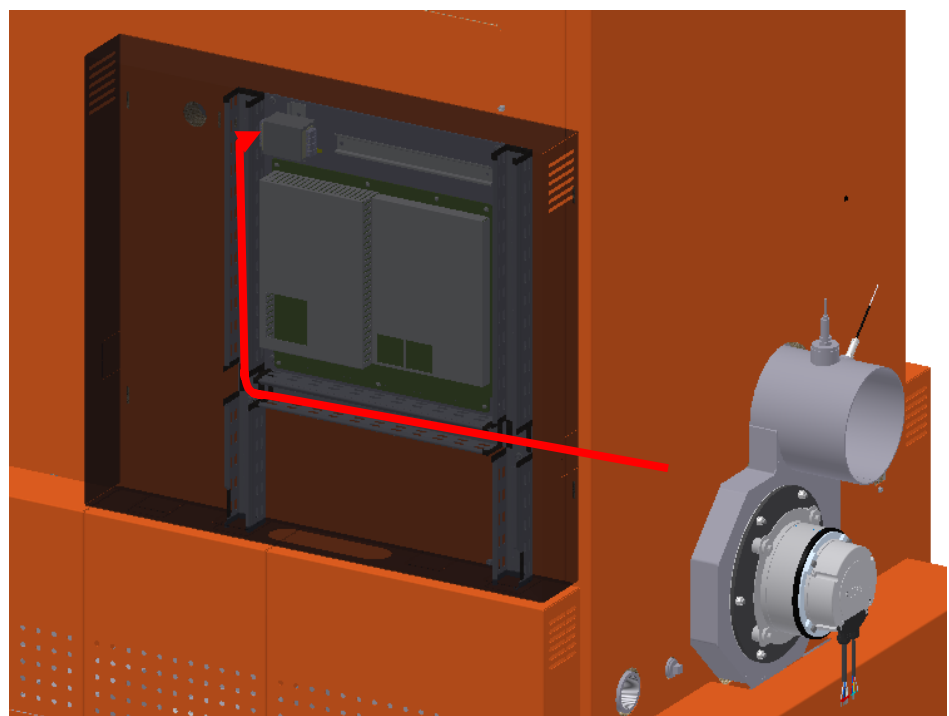

8.3 Mains connection

The mains supply line must be connected directly to the mains filter and the earth terminal provided for this purpose.

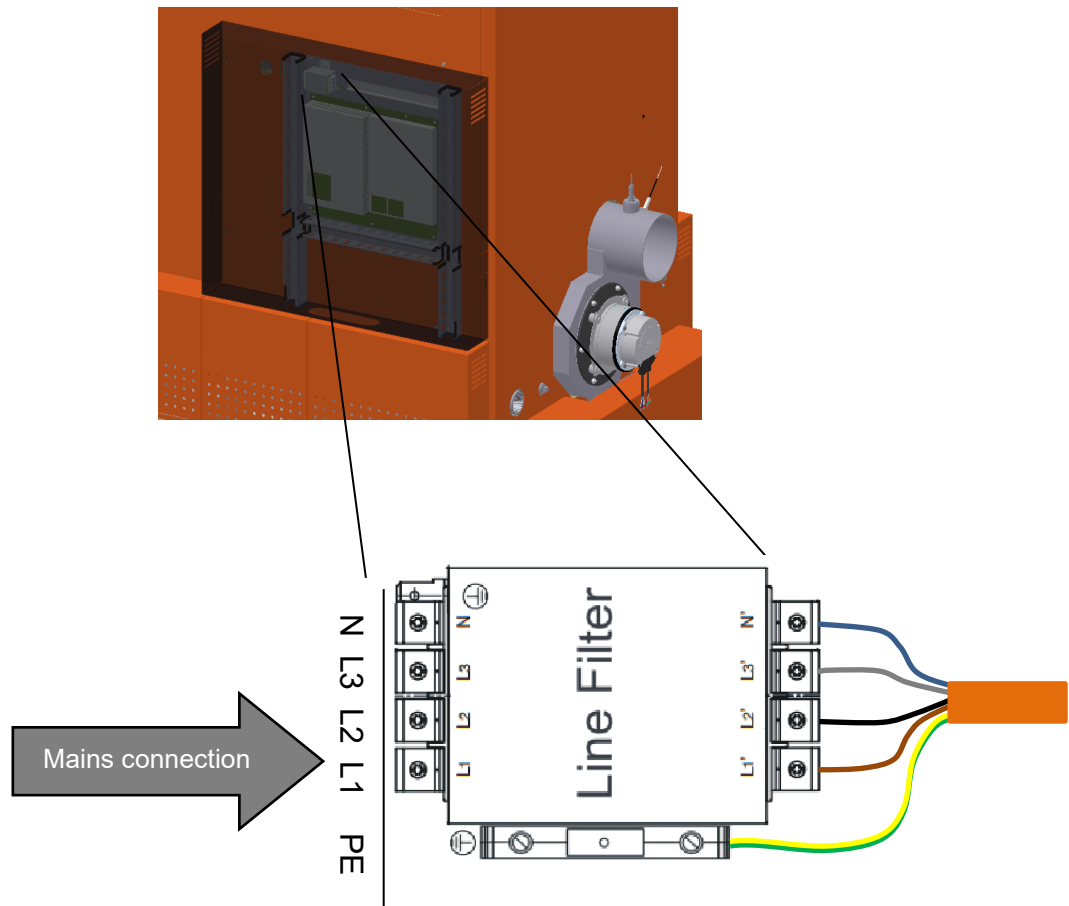

9 Hydraulic requirements

9.1 Hot water heating systems up to 110°C - diffusion-tight

To prevent damage, especially due to scale deposits on the boiler system, circulating water must meet the following conditions during new fills and refills (SWKI Directive BT 102-01):

9.1.1 Requirements for the filling and top-up water



Caution:

To prevent damage to safety devices during filling or refilling, the inlet water pressure must be limited to the permissible operating pressure, see **technical data**.

Nom.	Nomenclature	Setpoint	Unit
GH	Total hardness	< 0.1 ^{a)}	mmol/l
LF	Conductivity	< 100	µS/cm
pH	pH value	6.0 ... 8.5	-

Explanatory notes:

- a) The filling and make-up water must be desalinated.

9.1.2 Requirements for circulating water



Caution:

The circulating water must be checked annually. Additionally, comply with the applicable country-specific norms.

Nom.	Nomenclature	Setpoint	Unit
GH	Total hardness	< 0.5	mmol/l
LF	Conductivity	< 200 ^{b)}	µS/cm
pH	pH value	8.2 ... 10 ^{c)}	-
Cl ⁻	Chlorides (Cl)	< 30 ^{d)}	mg/l
SO ₄ ²⁻	Sulphates	< 50 ^{d)}	mg/l
O ₂	Oxygen	< 0.1 ^{e)}	mg/l
Fe	Iron dissolved	< 0.5	mg/l
TOC	Total organic carbon content	< 30	mg/l

Explanatory notes:

- b) Higher values are permissible when using conditioning agents.
- c) It is generally not necessary to alkalise the filling and make-up water, as the pH value of the process water will be within the specified range within a few weeks of operation due to its own alkalisation. First check of the pH value after 2 months, at the latest during the next annual maintenance. If a pH correction is carried out (normal case: Raising), it should be noted that system parts or components consisting of aluminium alloys have a maximum target pH value of 8.5. Inorganic alkalisating agents should be used for this purpose. Organic substances often have unfavourable side effects, such as impairing sealing materials or promoting the microbiological activity of the water.
- d) For water with a high chloride or sulphate content, the best technical solution is demineralisation (full demineralisation).
- e) In systems of the given type, an oxygen content within the target value range is usually achieved spontaneously. High oxygen levels promote oxygen corrosion, which manifests itself as “rust water” and can lead to malfunctions. The measures are a matter for the specialist. A good technical and ecological solution: Sacrificial anode protection process.

9.1.3 Water Treatment of Different Raw Waters



- Up to 20°f → Addition of hardness stabilisers and alkalisating agents
- Over 20°f → Softening by base exchange to 0°f hardness and addition of alkalisating agents. For large systems (e.g., district heating), possibly full desalination and additional alkalisation.
- The circulating water must be checked annually. Additionally, comply with the applicable country-specific norms.

9.2 Thermal discharge safety TAS

When integrating the boiler unit in a closed heating system, the temperature relief valve is responsible for ensuring that the heat from the boiler is discharged through the cooling water; heat can develop due to, for instance, a defect in the open loop/closed loop control system and associated continued burning at nominal load or in the event of a power outage with a natural draft fire resulting from it.



The equipment for removing excessive heat has to be serviced and tested once a year by a qualified person.

The water supply must be ensured at all times.

A drinking water system separator has to be integrated into the extinguishing water supply in accordance with country-specific regulations.



Attention!

Ensure that the drain of the thermal discharge safety is directed through a temperature-resistant line to prevent scalding!
The heat exchanger must not be used as a water heater.

Schematic diagram of thermal drainage safety device

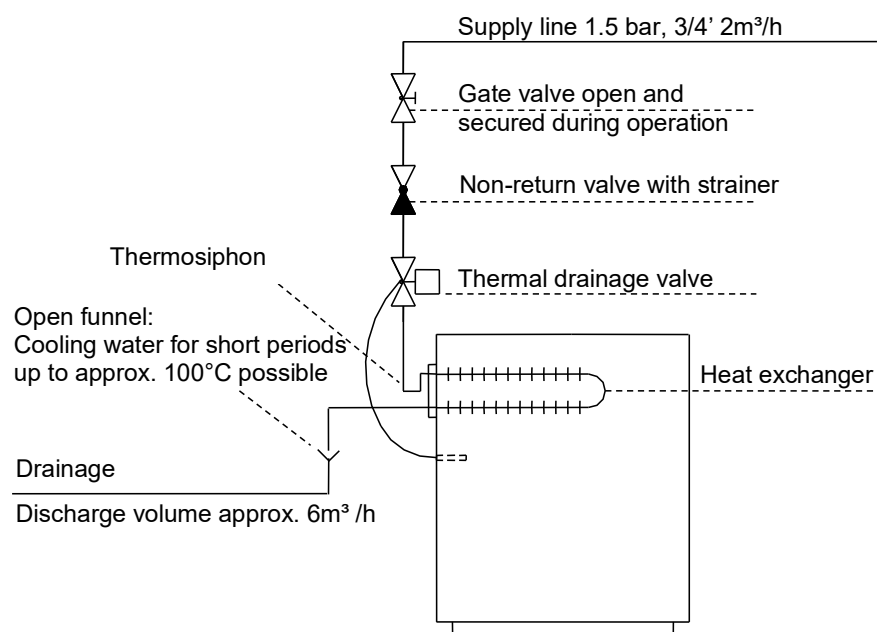

9.3 Thermally activated extinguishing system

A thermal valve with a contact sensor (electrically independent) must be installed at the extinguishing water connection, and the contact sensor must be placed directly on the stoker in the designated protective tube. If the temperature in the stoker is $>65^{\circ}\text{C}$, the extinguishing water valve opens automatically and the backfire is extinguished. The extinguishing water valve closes automatically if the temperature drops back below the trip point.

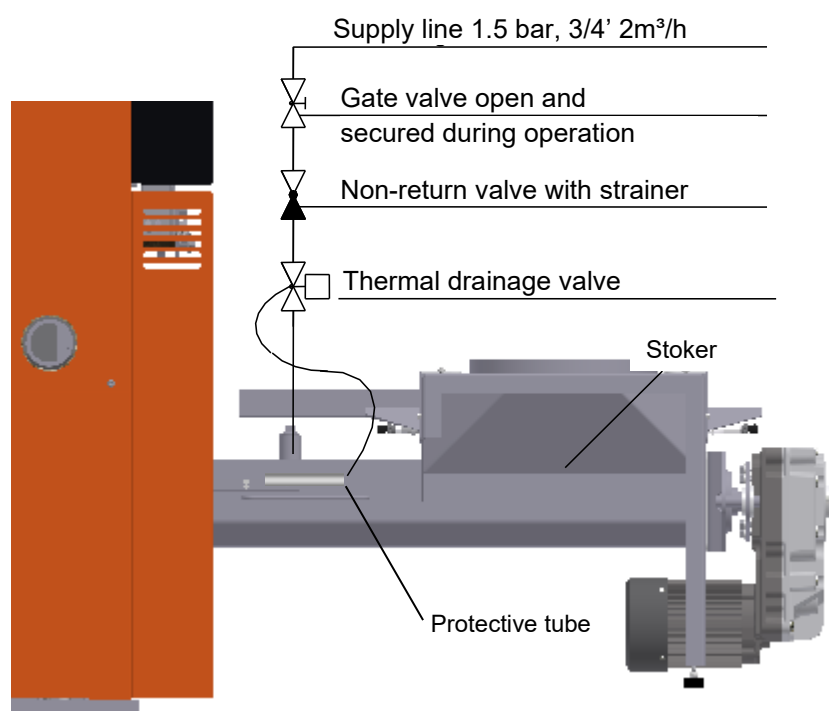

The thermally activated extinguishing system has to be serviced and tested once a year by a qualified person.

The water supply must be ensured at all times.

A drinking water system separator has to be integrated into the extinguishing water supply in accordance with country-specific regulations.

Furthermore, the valid country-specific regulations regarding the installation of the extinguishing device must be observed.

9.4 Buffer

Use of a Buffer Tank

When calculating the heat demand of buildings, for example, according to DIN EN 12831 “Procedure for calculating the standard heat load,” the lowest outside temperature of the respective climate zone (e.g., -15°C) is assigned. However, these conditions only occur on a few days of the year, so that a heating system is oversized in terms of its heat output during most heating days. For this reason, the UTSD heating system is equipped with power control and automatic ignition as standard.

The size of the buffer tank depends on the nominal heat output of the boiler and the heat demand of the building. As a guideline, 25 litres per kilowatt of boiler output can be taken. This results in a burn time of the boiler of approximately 1.25 hours at full load operation, during which the buffer tank is completely filled. The discharge time of the buffer tank at 25% nominal load is approximately 4 hours in this design case, assuming a usable temperature difference of 40 Kelvin. One advantage of using a buffer tank is the low operating hours of the system and fewer start-up phases due to extended heating intervals, resulting in a low external energy share and low wear of mechanical parts.

Another advantage of a buffer tank is in summer operation, i.e., only domestic hot water preparation. In this operating mode, frequent on/off operation is avoided by a buffer tank.



For the reasons listed above, Schmid AG requires a buffer tank in accordance with the Air Pollution Control Ordinance (LRV).

Country-specific Requirements:

Air Pollution Control Regulation (LRV)

The minimum storage volume is determined according to the Swiss Air Pollution Control Regulation (LRV) of December 16, 1985 (as of April 16, 2019) as follows:

Automatic boilers up to 500 kW nominal heat output must be equipped with a heat storage tank with a volume of at least 25 litres per kW nominal heat output. Excluded from this are boilers for wood pellets up to 70 kW firing heat output.

This results in the following minimum storage volumes:

UTSD (wood chips/ pellets)	Minimum storage volume:
240/110	2750 l
240/115	2875 l
240/120	3000 l
240/140	3500 l
240/145	3625 l
240/150	3750 L
240/160	4000 l
240/180	4500 l
240/200	5000 l
240/220	5500 L
240/240	6000 l
240/250	6250 l
240/260	6500 l

The authority may establish smaller storage sizes if this is indicated for technical or operational reasons.

If multiple individual furnaces are operated as a single operational unit for the purpose of covering a variable heat demand in changing configurations, the authority may establish smaller storage sizes.



Caution:

Additionally, comply with the applicable country-specific norms. However, the storage volumes must not fall below the minimum storage volumes specified in the Ordinance on Air Pollution Control (LRV).

9.5 Hydraulic Integration



The dimension of the pipelines must be adapted to the local conditions. Pay attention to the water-side connections of the boiler for flow and return.

The boiler may only be installed in a closed hydraulic system.

The pipe dimension and routing are determined by the heating planner or heating installer. Depending on the pipe lengths and static heights (e.g., storage location), the pump and valve size should be adjusted as needed.

Return Temperature Increase

The installation of a return temperature increase is mandatory, as without a hydraulic group, the control behaviour of the boiler in connection with the AutomaticControl regulator does not function properly. In general, excessively low operating temperatures significantly shorten the lifespan of a boiler. Especially in the area of water-cooled downstream heating surfaces, where the exhaust gas temperatures are already relatively low, the water vapour contained in the exhaust gas is condensed as condensate when the dew point is undershot. This condensate causes corrosion and shortens the lifespan of the boiler. Corrosion due to condensation is avoided by the following measures:

- The flow temperature is kept high by the controller.
- The return temperature is kept above the dew point by the mandatory return temperature increase.



A buffer sensor F4 is mandatory for the correct function of the return flow boost.

10 Product data according to regulations (EU) 2015/1187 and 2015/1189

10.1 Information on wood chip / pellet firing

UTSD 240 /	Unit	145	150	160	180	200
------------	------	-----	-----	-----	-----	-----

Design data for wood chips as fuel

Useful heat output

		145.2	150	160	180	200
At nominal heat output	kW	145.2	150	160	180	200
Minimum heat output	kW	43.1	43.1	43.1	43.1	43.1
Buffer volume min. (45*P _r *(1-(2.7/P _r)))	l	6413	6629	7079	7979	8879
Condensing boiler		No				
Boiler With cogeneration		No				
Combi boiler		No				
Value for II (factor boiler/addition)		0				
Value for III (294/(11*P _r))		0.18	0.18	0.17	0.15	0.13
Value for IV (115/(11*P _r))		0.07	0.07	0.07	0.07	0.07
Preferred fuel		Wood chips according to EN ISO 17225-4:2021, A1 P45 F05 M25 A1.0 L150				
Other fuels		None				

Efficiency

		82	82	82	82	82
Annual space heating efficiency	%	82	82	82	82	82
Energy efficiency index (EEI) Boiler		121	121	121	121	121
Boiler energy efficiency class		A+	A+	A+	A+	A+
Energy efficiency index (EEI) boiler + controller (VI)		125	125	125	125	125
Energy efficiency class boiler + controller (VI)		A++	A++	A++	A++	A++

Fuel efficiency (in relation to the calorific value)

		84.7	84.7	84.8	84.9	85.0
At nominal heat output	%	84.7	84.7	84.8	84.9	85.0
At minimum heat output	%	87.0	87.0	87.0	87.0	87.0

Electrical power consumption (auxiliary power consumption)

		0.434	0.439	0.449	0.471	0.492
At nominal heat output	kW	0.434	0.439	0.449	0.471	0.492
At minimum heat output	kW	0.284	0.284	0.284	0.284	0.284
(Option fine dust separator)	kW	0.028	0.028	0.028	0.028	0.028
Stand-by	kW	0.014	0.014	0.014	0.014	0.014

Annual space heating emissions (10% O₂)

		7 (1)	7 (1)	8 (1)	8 (2)	9 (2)
Dust (with fine dust separator option)	mg/m ³	7 (1)	7 (1)	8 (1)	8 (2)	9 (2)
OGC	mg/m ³	1	1	1	1	1
CO	mg/m ³	13	13	12	12	11
NO _x	mg/m ³	104	105	107	112	117

For further emission data related to other O₂ values, see chapters 1.3 and 2.1

Wood chip and pellet firing

UTSD 240

Product data according to regulations (EU) 2015/1187 and 2015/1189

UTSD 240 /	Unit	220	240	250	260	-
------------	------	-----	-----	-----	-----	---

Design data for wood chips as fuel

Useful heat output

At nominal heat output	kW	220	240	250	259.3	-
Minimum heat output	kW	43.1	43.1	43.1	43.1	-
Buffer volume min. (45°P _r *(1-(2.7/P _r)))	l	9779	10679	11129	11547	-
Condensing boiler		No				
Boiler With cogeneration		No				
Combi boiler		No				
Value for II (factor boiler/addition)		0				
Value for III (294/(11°P _r))		0.12	0.11	0.11	0.10	-
Value for IV (115/(11°P _r))		0.07	0.07	0.07	0.07	-
Preferred fuel		Wood chips according to EN ISO 17225-4:2021, A1 P45 F05 M25 A1.0 L150				
Other fuels		None				

Efficiency

Annual space heating efficiency	%	82	82	82	82	-
Energy efficiency index (EEI) Boiler		122	122	122	122	-
Boiler energy efficiency class		A+	A+	A+	A+	-
Energy efficiency index (EEI) boiler + controller (VI)		126	126	126	126	-
Energy efficiency class boiler + controller (VI)		A++	A++	A++	A++	-

Fuel efficiency (in relation to the calorific value)

At nominal heat output	%	85.2	85.2	85.2	85.3	-
At minimum heat output	%	87.0	87.0	87.0	87.0	-

Electrical power consumption (auxiliary power consumption)

At nominal heat output	kW	0.513	0.535	0.545	0.555	-
At minimum heat output	kW	0.284	0.284	0.284	0.284	-
(Option fine dust separator)	kW	0.029	0.029	0.029	0.029	-
Stand-by	kW	0.014	0.014	0.014	0.014	-

Annual space heating emissions (10% O₂)

Dust (with fine dust separator option)	mg/m ³	10 (2)	10 (2)	11 (2)	11 (2)	-
OGC	mg/m ³	1	1	1	1	-
CO	mg/m ³	11	10	10	10	-
NO _x	mg/m ³	121	126	128	131	-

For further emission data related to other O₂ values, see chapters 1.3 and 2.1

Wood chip and pellet firing

UTSD 240

Product data according to regulations (EU) 2015/1187 and 2015/1189

UTSD 240 /	Unit	110	115	120	140	145
Pellets as fuel						
Useful heat output						
At nominal heat output	kW	112	115	120	140	145
Minimum heat output	kW	32	32	32	32	32
Buffer volume min. (45°P ₁ *(1-(2.7/P ₁)))	l	4919	5054	5279	6179	6404
Condensing boiler		No				
Boiler With cogeneration		No				
Combi boiler		No				
Value for II (factor boiler/addition)		0				
Value for III (294/(11°P ₁))		0.24	0.23	0.22	0.19	0.18
Value for IV (115/(11°P ₁))		0.09	0.09	0.09	0.07	0.07
Preferred fuel		Pellets according to EN ISO 17225-2 class A1 D06, M10, A0.7				
Other fuels		None				
Efficiency						
Annual space heating efficiency	%	86	86	86	86	86
Energy efficiency index (EEI) Boiler		126	126	126	126	126
Boiler energy efficiency class		A++	A++	A++	A++	A++
Energy efficiency index (EEI) boiler + controller (VI)		130	130	130	131	131
Energy efficiency class boiler + controller (VI)		A++	A++	A++	A++	A++
Fuel efficiency (in relation to the calorific value)						
At nominal heat output	%	89.1	89.1	89.0	88.9	88.9
At minimum heat output	%	90.2	90.2	90.2	90.2	90.2
Electrical power consumption (auxiliary power consumption)						
At nominal heat output	kW	0.265	0.267	0.269	0.280	0.283
At minimum heat output	kW	0.206	0.206	0.206	0.206	0.206
(Option fine dust separator)	kW	0.021	0.028	0.028	0.028	0.028
Stand-by	kW	0.014	0.014	0.014	0.014	0.014
Annual space heating emissions (10% O₂)						
Dust (with fine dust separator option)	mg/m ³	5 (1)	5 (1)	5 (1)	5 (1)	5 (1)
OGC	mg/m ³	1	1	1	1	1
CO	mg/m ³	7	7	7	5	5
NO _x	mg/m ³	130	130	131	135	136

For further emission data related to other O₂ values, see chapters 1.3 and 2.1

Wood chip and pellet firing

UTSD 240

Product data according to regulations (EU) 2015/1187 and 2015/1189

UTSD 240 /	Unit	150	160	180	200	220
Pellets as fuel						
Useful heat output						
At nominal heat output	kW	150	160	180	196,8	220
Minimum heat output	kW	32	32	32	32	32
Buffer volume min. (45°P ₁ *(1-(2.7/P ₁)))	l	6629	7079	7979	8735	9779
Condensing boiler		No				
Boiler With cogeneration		No				
Combi boiler		No				
Value for II (factor boiler/addition)		0				
Value for III (294/(11°P ₁))		0.18	0.17	0.15	0.14	0.12
Value for IV (115/(11°P ₁))		0.07	0.07	0.06	0.05	0.05
Preferred fuel		Pellets according to EN ISO 17225-2 class A1 D06, M10, A0.7				
Other fuels		None				
Efficiency						
Annual space heating efficiency	%	86	86	86	86	86
Energy efficiency index (EEI) Boiler		126	126	126	126	127
Boiler energy efficiency class		A++	A++	A++	A++	A++
Energy efficiency index (EEI) boiler + controller (VI)		131	131	131	130	131
Energy efficiency class boiler + controller (VI)		A++	A++	A++	A++	A++
Fuel efficiency (in relation to the calorific value)						
At nominal heat output	%	88.9	88.9	88.8	88.7	87.8
At minimum heat output	%	90.2	90.2	90.2	90.2	90.2
Electrical power consumption (auxiliary power consumption)						
At nominal heat output	kW	0.286	0.291	0.302	0.311	0.361
At minimum heat output	kW	0.206	0.206	0.206	0.206	0.206
(Option fine dust separator)	kW	0.028	0.028	0.028	0.028	0.029
Stand-by	kW	0.014	0.014	0.014	0.014	0.014
Annual space heating emissions (10% O₂)						
Dust (with fine dust separator option)	mg/m ³	5 (1)	5 (1)	5 (1)	5 (1)	5 (1)
OGC	mg/m ³	1	1	1	1	1
CO	mg/m ³	5	4	3	2	2
NO _x	mg/m ³	136	138	142	145	147

For further emission data related to other O₂ values, see chapters 1.3 and 2.1

Wood chip and pellet firing

UTSD 240

Product data according to regulations (EU) 2015/1187 and 2015/1189

UTSD 240 /	Unit	240	250	260	-	-
Pellets as fuel						
Useful heat output						
At nominal heat output	kW	240	250	255.2	-	-
Minimum heat output	kW	32	32	32	-	-
Buffer volume min. (45°P ₁ *(1-(2.7/P ₁)))	l	10679	11129	11363	-	-
Condensing boiler		No				
Boiler With cogeneration		No				
Combi boiler		No				
Value for II (factor boiler/addition)		0				
Value for III (294/(11°P ₁))		0.11	0.11	0.10	-	-
Value for IV (115/(11°P ₁))		0.04	0.04	0.04	-	-
Preferred fuel		Pellets according to EN ISO 17225-2 class A1 D06, M10, A0.7				
Other fuels		None				
Efficiency						
Annual space heating efficiency	%	86	86	86	-	-
Energy efficiency index (EEI) Boiler		126	126	126	-	-
Boiler energy efficiency class		A++	A++	A++	-	-
Energy efficiency index (EEI) boiler + controller (VI)		130	130	130	-	-
Energy efficiency class boiler + controller (VI)		A++	A++	A++	-	-
Fuel efficiency (in relation to the calorific value)						
At nominal heat output	%	87.0	86.6	86.2	-	-
At minimum heat output	%	90.2	90.2	90.2	-	-
Electrical power consumption (auxiliary power consumption)						
At nominal heat output	kW	0.405	0.427	0.438	-	-
At minimum heat output	kW	0.206	0.206	0.206	-	-
(Option fine dust separator)	kW	0.029	0.029	0.029	-	-
Stand-by	kW	0.014	0.014	0.014	-	-
Annual space heating emissions (10% O₂)						
Dust (with fine dust separator option)	mg/m ³	5 (1)	5 (1)	5 (1)	-	-
OGC	mg/m ³	1	1	1	-	-
CO	mg/m ³	2	2	2	-	-
NO _x	mg/m ³	150	151	151	-	-

For further emission data related to other O₂ values, see chapters 1.3 and 2.1

11 Dismantling, recycling and disposal

11.1 General information



Notes on dismantling, recycling and disposal

When decommissioning or modifying a system, the dismantled system components or assemblies, if not reusable, must be disposed of in accordance with regulations. Otherwise they must be recycled.

The system primarily consists of the following materials:

- Structural steel and sheet steel
- Steel and grey cast iron
- Concrete (lining)
- Insulation material
- Ash/slag residues
- Electrical and electronic components

The system or system components must be professionally dismantled. Recyclable materials must be separated and recycled in a clean condition. Non-recyclable materials and system components must be disposed of in accordance with regulations. The local regulations for the disposal and recycling of operating resources, operating materials, residual materials and system parts must be complied with.

11.2 Safety Regulations

After shutting down the system, the electrical power supply must be safely disconnected. In addition, the safety regulations described in the operating instructions in the section on safety also apply.

11.3 Recommendation for dismantling of the system or system

Components

Schmid AG strongly recommends having the dismantling work carried out by our specialised personnel. Schmid AG disclaims any liability for consequential damage to persons, machinery, buildings, etc., resulting from improper execution by third parties.