

>> PELLETRONIC PESS

>> LIGNUMAT UTSL

Full of energy!
Pellet / wood chip firing systems





HEATING IN HARMONY WITH NATURE

If you heat with wood, you are heating in harmony with nature. In contrast to the fossil fuels oil and gas, wood as a fuel has a zero carbon footprint. This helps the climate, boosts the national economy and optimises the condition of our forests. For a well managed forest is a healthy forest.

Ruinous depletion of resources

Nature needed several hundred million years to build up fossil energy. We are plundering and burning these stocks in just a few generations. This releases pollutants and causes global warming.



A harmonious cycle

Wood energy means: a cycle, not depletion. When wood is cut, it grows back again and binds as much CO₂ as was set free when it was burnt.



CUTTING EDGE TECHNOLOGY AT A GLANCE

The tried-and-tested Schmid firing systems for pellets and wood chips set standards in combustion technology and are extremely user-friendly. If you care for the environment, you will choose wood as an energy source. The latest technology means the demand for clean combustion can be easily satisfied. Schmid firing systems are noted for their high efficiency, and their cost effectiveness. The broad range of furnace types covers various operating ranges and requirements.



Pellets – fuel from untreated wood with excellent thermal properties.

The cylindrical pellets are pressed from sawdust and wood shavings without chemical additives. The density of pellets is 1.5 to 2 times higher than that of logs. 2 kg of pellets replace 1 litre of heating oil. Pellets can be loaded automatically. There is a reliable nationwide supply throughout the year.



Wood chips – wood felled locally is processed on site into wood chips and transported to the consumer.

The trees are stored for several months after felling but are not defoliated; this pre-dries the wood to a significant level. There is a reliable nationwide supply all year round. Various discharge mechanisms from the silo to the boiler room guarantee easy, fully automated operation of the system.



Pelletronic PESS, 8 – 25 kW
Pellets



Lignumat UTSL, 30 – 150 kW
Pellets / wood chips



Lignumat UTSL, 250 kW
Pellets / wood chips

PELLETRONIC PESS

PELLET FIRING SYSTEM

1. Fan
2. Pellet feed
3. Container / hopper
4. Drive unit for stoker screw and rotary valve
5. Rotary valve for perfect backfire protection
6. Stoker screw
7. Rotary grate burner
8. Automatic ignition
9. Durable stainless steel combustor
10. Long-term optimum efficiency through automatic cleaning of heat exchanger tubes
11. Flue gas pipe connection
12. Drive unit for automatic cleaning / de-ashing
13. Ash tray
14. Flow and return connections
15. Control unit with clear display (standard combustion control via lambda sensor, automatic ignition via heater filament)
16. Main switch



Highlights

- >> Maximum efficiency and ease of use
- >> Flexible installation in the boiler room
- >> Small footprint



Boiler type	Nominal output kW	Operating range kW	Dimensions in mm	Weight in kg
PESS-8	7.9	2.4 – 7.9	H: 1500 / B: 1080 / T: 700	350
PESS-12	12.0	2.5 – 12.0	H: 1500 / B: 1080 / T: 700	350
PESS-15	14.9	3.9 – 14.9	H: 1500 / B: 1080 / T: 700	350
PESS-25	23.5	3.9 – 23.5	H: 1500 / B: 1080 / T: 700	350

Information for users:

Fully automated

- >> The pellets are transported directly from the pellet store to the combustion chamber
- >> Automatic start-up as required according to the outside temperature
- >> Always offers the performance you require thanks to its modulating mode of operation
- >> Self-cleaning boiler

Intelligent control unit with clear display. The system can be controlled optionally via remote control from your living room or via a modem from remote location. The optimum operating mode can be selected at the push of a button.

Information for the owner:

- >> The Pelletronic PESS is a high quality product, offering operating reliability and a long service life
- >> No-wear, especially durable stainless steel combustor with rotary grate
- >> The automatic cleaner function of the heat exchanger guarantees a constant high level of efficiency
- >> The Pelletronic PESS is ideally suited for combined operation with solar thermal – the control system includes the necessary storage management
- >> The product is type tested and complies with the strict EU regulations as well as the requirements of Holzenergie Schweiz (quality seal)
- >> A reliable supply of pellets is available (the country)

Information for engineers:

- >> Combustion control via lambda sensor
- >> Burn back protection with steel rotary valve
- >> Air infeed with negative pressure via speed-controlled induced draught fan
- >> Weather-controlled flow temperature control (plug'n'go wiring)
- >> Up to 8 different heat circuits
- >> Individual control modules with bus line to main cabinet, can be dismantled at any time
- >> Hot water control for unlimited number of water heaters, with priority switching and legionella program

Storage

There are various pellet storage options available:



Pellet store room with suction pipes



Central screw discharge



Fabric silo



Underground tank

Discharge / conveyor system

The Pelletronic PESS is fitted with an integrated storage container. The wood pellets are transported via a fully automatic suction system from the pellet store to the hopper and from there to the rotary grate burner via the stoker screw.

The integrated rotary valve ensures perfect burn back protection. The suction conveyor system gives you plenty of room for planning and construction, both in the boiler room as well as in the storage room (hose length of up to 20 metres is absolutely no problem).

LIGNUMAT UTSL up to 150 kW

PELLET / WOOD CHIP FIRING SYSTEM

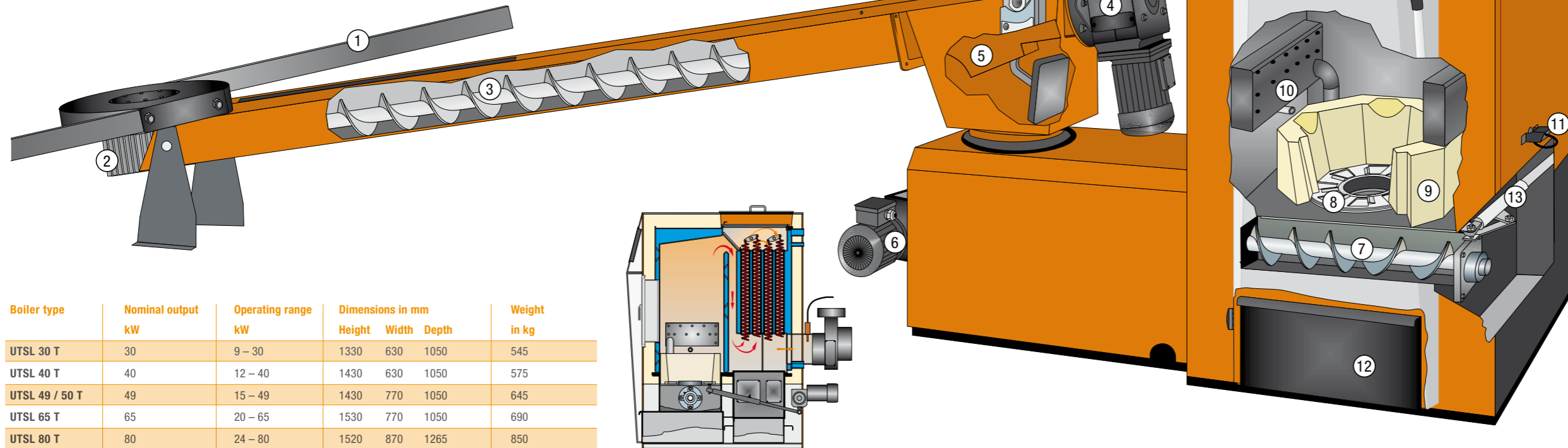

Boiler type	Nominal output kW	Operating range kW	Dimensions in mm			Weight in kg
			Height	Width	Depth	
UTSL 30 T	30	9 – 30	1330	630	1050	545
UTSL 40 T	40	12 – 40	1430	630	1050	575
UTSL 49 / 50 T	49	15 – 49	1430	770	1050	645
UTSL 65 T	65	20 – 65	1530	770	1050	690
UTSL 80 T	80	24 – 80	1520	870	1265	850
UTSL 99 / 110 T	110	30 – 100	1620	870	1265	950
UTSL 150 T	150	45 – 150	1810	1050	1465	1400

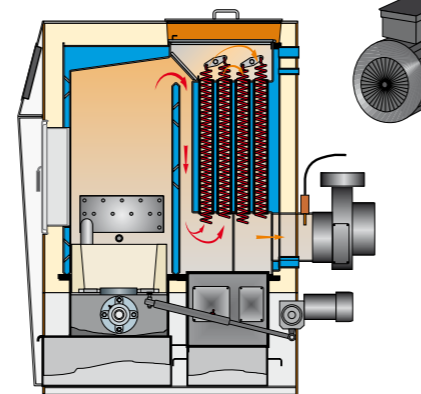

Boiler with 4 rows of pipes in heat exchanger

1. Spring arms
2. Angular gear gearbox
3. Transport screw
4. Drive for silo discharge
5. Burn back flap with emergency control
6. Drive unit for stoker screw
7. Stoker screw
8. Rotary grate burner with automatic de-ashing
9. Shaped fire bricks
10. Secondary combustion zone
11. Optical combustion chamber control
12. Ash tray
13. Ash removal mechanism
14. Boiler cabinet with insulation
15. Control unit

Information for users:

- >> Shaped fire bricks will low thermal mass ensure rapid response time of the boiler
- >> Fully automatic cleaning of burner and heat exchanger
- >> The ash is removed automatically to the ash tray or alternatively to a separate container
- >> Automatic start-up according to the outside temperature, if required with ignition fan

Information for the owner:

- >> Maximum efficiency (> 93%) thanks to low flue gas temperature and clean combustion
- >> Optimum combustion at all times, even with different fuel types
- >> Long life expectancy thanks to reliable product quality
- >> The product is type tested and complies with the strict EU regulations as well as the requirements of Holzenergie Schweiz (quality seal)
- >> High level of safety due to certified burn back flap

Information for engineers:

- >> Patented burner system with rotary grate for easy de-ashing
- >> Combustion control with optical combustion chamber monitoring
- >> Vertical heat exchangers
- >> The lambda sensor allows for fine calibration to suit the fuel

Microprocessor control



The control unit optimises combustion and energy management

- >> Clearly arranged display
- >> Switch functions at the push of a button
- >> Lambda sensor for uninterrupted combustion
- >> Utilisation of residual heat
- >> Fault indicator with signal
- >> Display screen saver program
- >> Plug'n'go wiring

Weather-controlled flow temperature control

- >> Up to 16 different heat circuits
- >> Can be expanded at any time by adding individual control modules connected to the main cabinet via a bus line

Hot water control

- >> For an unlimited number of water heaters
- >> Priority switching and legionella program

Miscellaneous

- >> Storage management to include alternative energy sources (e.g. solar thermal systems)
- >> The whole system can be remote controlled from your living room or via modem from the office

LIGNUMAT UTSL up to 250 kW

PELLET / WOOD CHIP FIRING SYSTEM

1. Discharge screw
2. Discharge drive unit
3. Dump button with burn back flap or rotary valve
4. Stoker screw unit
5. Supply air fans for uninterrupted combustion
6. Control unit
7. Grate ash removal control
8. Rotary grate burner with automatic de-ashing
9. Low wear combustion chamber bricks
10. Heat exchanger with automatic cleaning function
11. Ash deposit chamber
12. De-ashing unit in ash container
13. Flue gas fan

Boiler type	Nominal output kW	Operating range kW	Dimensions in mm			Weight in kg
			Height	Width	Depth	
UTSL 250	245	75 – 245	1790	2630	2630	2300

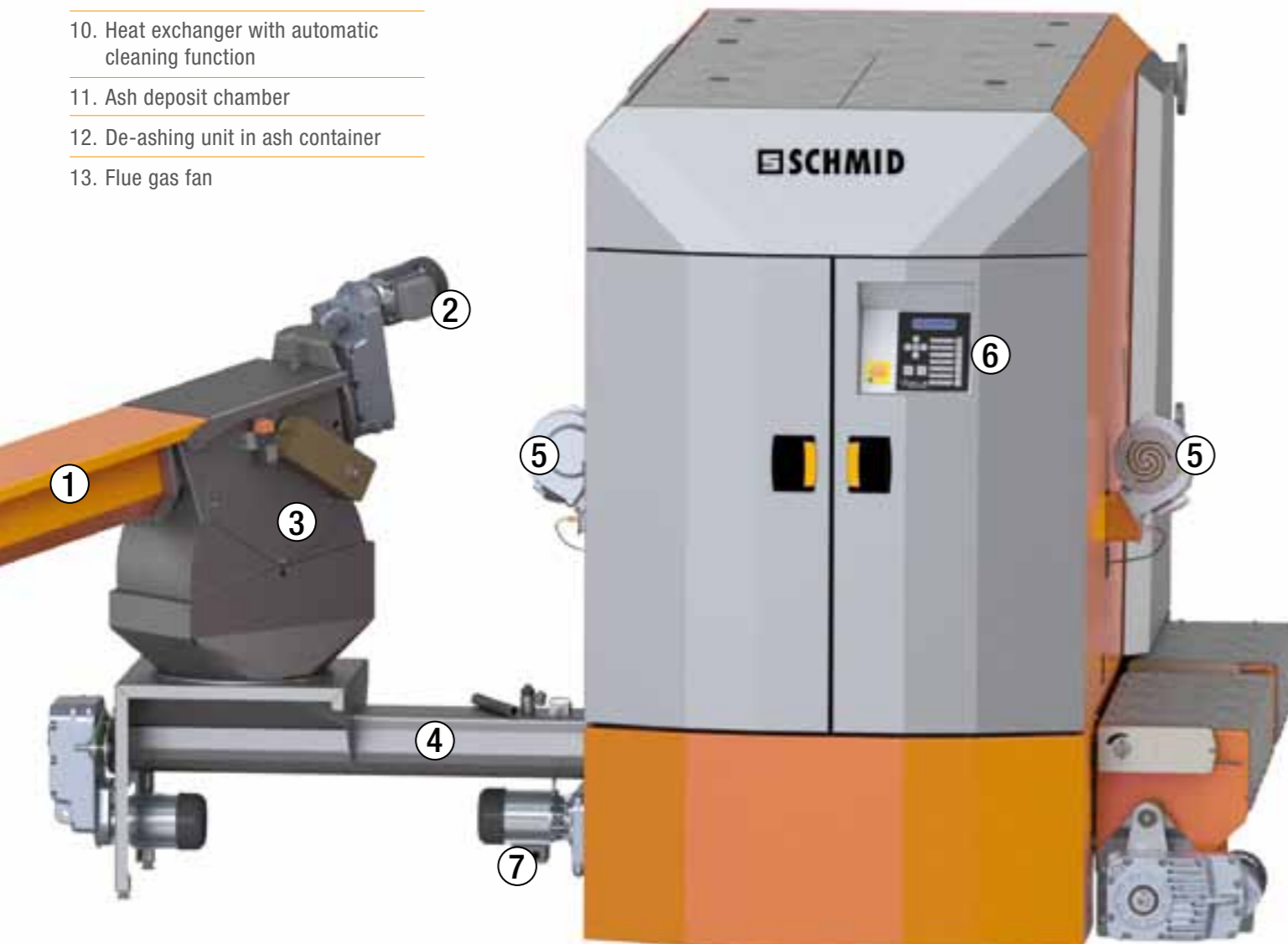

Microprocessor control



The control unit optimises combustion and energy management

- >> Clearly arranged display
- >> Switch functions at the push of a button
- >> Lambda sensor for uninterrupted combustion
- >> Utilisation of residual heat
- >> Fault indicator with signal
- >> Display screen saver program
- >> Plug'n'go wiring

Weather-controlled flow temperature control

- >> Up to 16 different heat circuits
- >> Can be expanded at any time by adding individual control modules connected to the main cabinet via a bus line

Hot water control

- >> For an unlimited number of water heaters
- >> Priority switching and legionella program

Miscellaneous

- >> Storage management to include alternative energy sources (e.g. solar thermal systems)
- >> The whole system can be remote controlled from your living room or via modem from the office

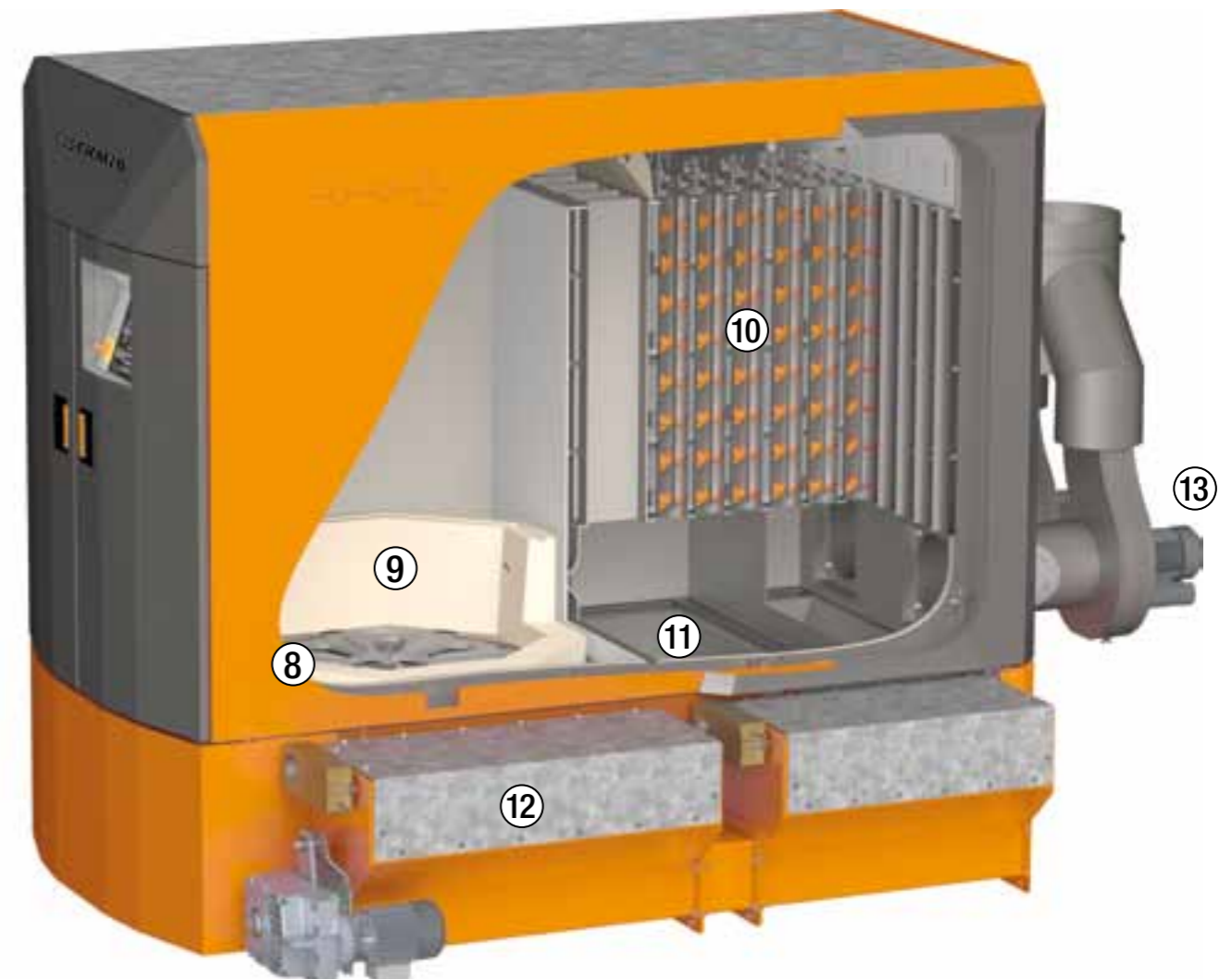

THE OPTIMAL FUEL INFEED

Silo discharge and conveyor systems are of great importance. Depending on the spatial conditions and the type of fuel used, we will offer you the perfect discharge system. The discharge systems are manufactured individually to your needs.

Silo clearing with angled screw

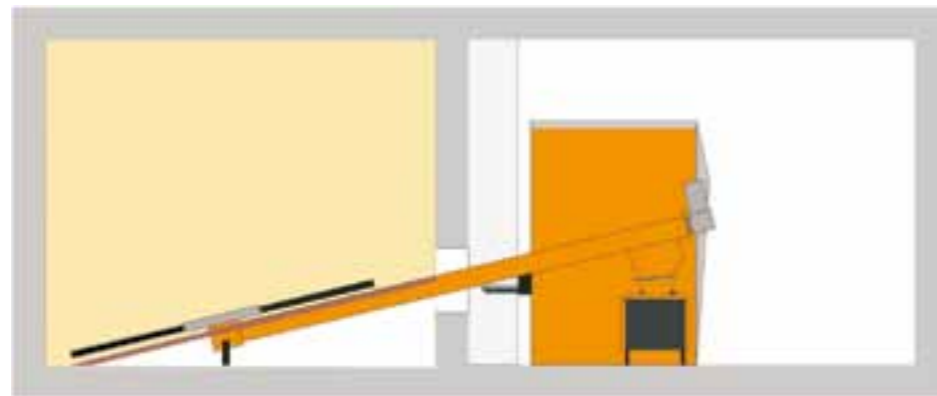

Silo clearing with inclined screw recessed in floor



DOAF discharge (double spring discharge) with inclined screw



Silo discharge on upper storey

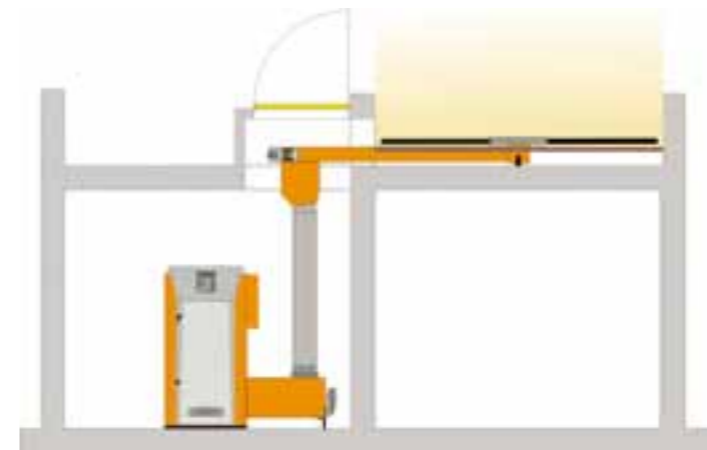

Single silo discharge with 2-screw discharge

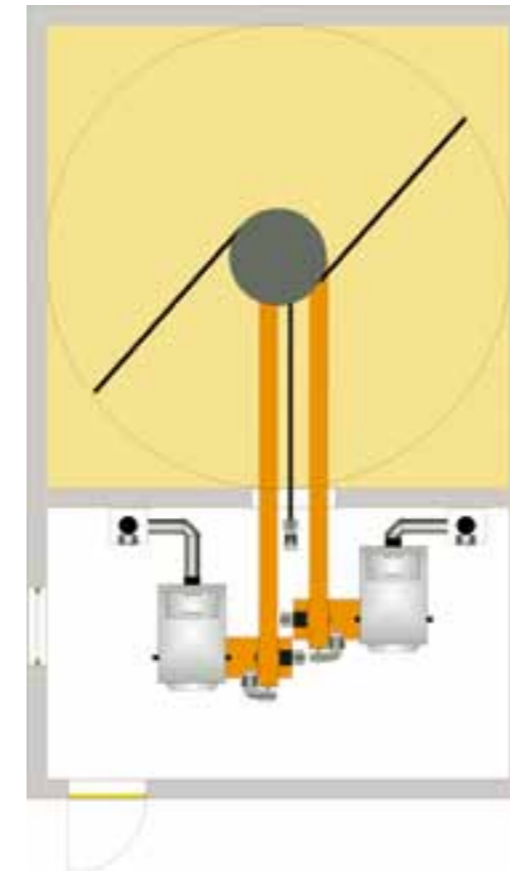

Double system

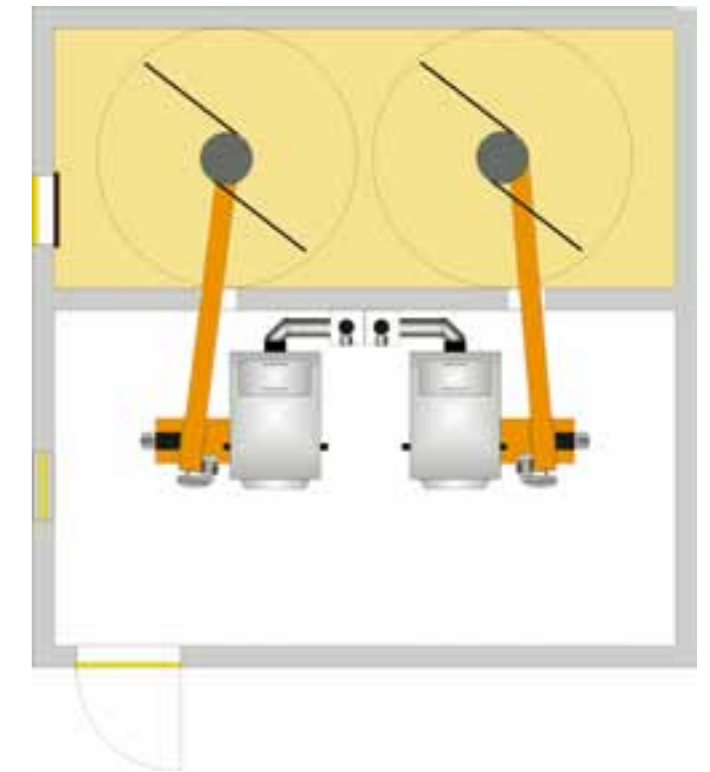

Silo discharge with transfer

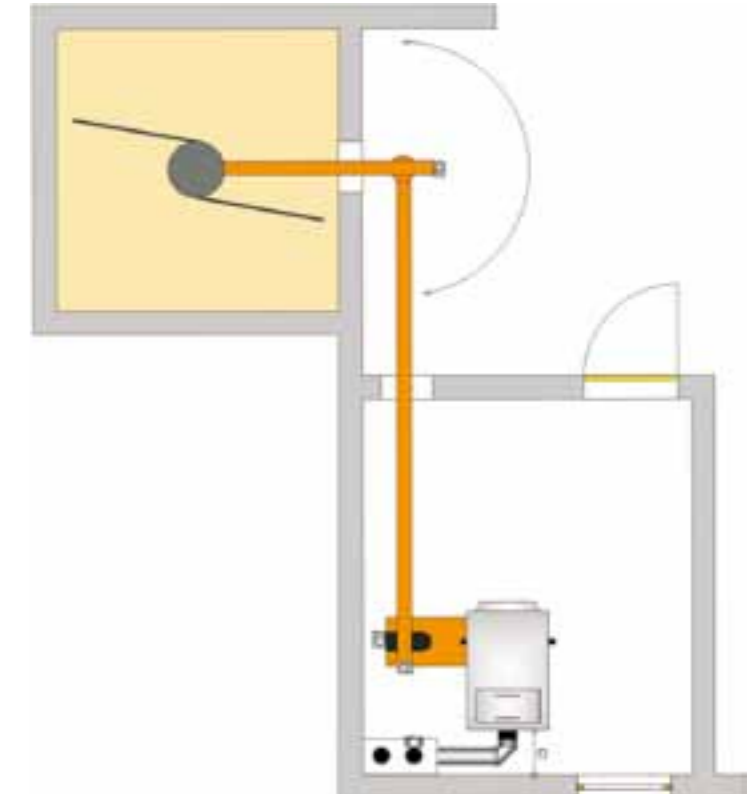

SCHMID ENERGY SOLUTIONS – FULL OF ENERGY

Schmid AG, energy solutions

Postfach 42
CH-8360 Eschlikon

Phone +41 (0)71 973 73 73
Fax +41 (0)71 973 73 70

www.schmid-energy.ch
info@schmid-energy.ch

Schmid AG, energy solutions

Industriestrasse 17
CH-4713 Matzendorf

Phone +41 (0)62 389 20 50
Fax +41 (0)62 389 20 51

Schmid SA, energy solutions

Rue St. Michel 10
CH-1510 Moudon

Phone +41 (0)21 905 35 55
Fax +41 (0)21 905 35 59

moudon@schmid-energy.ch

Schmid GmbH & Co. KG energy solutions

Kettenerstrasse 25
D-70794 Filderstadt

Phone +49 (0)711 70 956-0
Fax +49 (0)711 70 956-10

info@schmid-energy.de

Schmid France energy solutions

Quartier des Entrepreneurs
Aire de la Thur / Route de Guebwiller
F-68840 Pulversheim

Phone +33 (0)3 89 28 50 82
Fax +33 (0)3 89 48 04 90

info@schmid-energy.fr

Schmid Italia S.r.l.

C.so Repubblica, 5
I-10090 San Giorgio Canavese

Phone +39 (0)124 32 167
Fax +39 (0)124 51 85

info@schmid-energy.it

Schmid energy solutions GmbH

Hans-Thalhammer-Strasse 4
AT-8501 Lieboch

Phone +43 3136 61580
office@schmid-energy.at

SCHMID
energy solutions



The Swiss pioneer in wood firing systems

Schmid AG is a Swiss family business that has been involved with wood energy for 75 years and employs around 300 people. The headquarters are in Eschlikon. In addition to other offices in Switzerland, Schmid AG also has sales offices and service centres in Germany, Austria, France and Italy.

Over decades, Schmid has been at the forefront in the development of wood furnace technology. Today, the company is one of the leading companies in the industry.

